

Skal ligge i flyet!

**CESSNA**

MORE PEOPLE BUY AND  
FLY CESSNA AIRPLANES  
THAN ANY OTHER MAKE

**1969**

WORLD'S LARGEST PRO-  
DUCER OF GENERAL  
AVIATION AIRCRAFT  
SINCE 1956

**MODEL  
150**

DAG EDVARD LARSEN  
Vinkelveien 3  
2500 TYNSET  
Tlf. (064) 81 691

LN - LGB



**OWNER'S  
MANUAL**

# PERFORMANCE - SPECIFICATIONS

Model 150 *	STANDARD AND TRAINER	COMMUTER
GROSS WEIGHT . . . . .	1600 lbs	1600 lbs
SPEED:		
Top Speed at Sea Level . . . . .	122 mph	122 mph
Cruise, 75% Power at 7000 ft . . . . .	117 mph	117 mph
RANGE:		
Cruise, 75% Power at 7000 ft . . . . .	475 mi	475 mi
22.5 Gallons, No Reserve	4.1 hrs	4.1 hrs
	117 mph	117 mph
Cruise, 75% Power at 7000 ft . . . . .	725 mi	725 mi
Long Range Version, 35.0 Gallons	6.2 hrs	6.2 hrs
	117 mph	117 mph
Optimum Range at 10,000 ft . . . . .	565 mi	565 mi
22.5 Gallons, No Reserve	6.1 hrs	6.1 hrs
	93 mph	93 mph
Optimum Range at 10,000 ft . . . . .	880 mi	880 mi
Long Range Version, 35.0 Gallons	9.4 hrs	9.4 hrs
	93 mph	93 mph
RATE OF CLIMB AT SEA LEVEL . . . . .	670 fpm	670 fpm
SERVICE CEILING . . . . .	12,650 ft	12,650 ft
TAKE-OFF:		
Ground Run . . . . .	735 ft	735 ft
Total Distance Over 50-Ft Obstacle. . . . .	1385 ft	1385 ft
LANDING:		
Landing Roll . . . . .	445 ft	445 ft
Total Distance Over 50-Ft Obstacle. . . . .	1075 ft	1075 ft
EMPTY WEIGHT: (Approximate)	Standard	Trainer
With Standard Fuel Tanks . . . . .	975 lbs	1005 lbs
With Long Range Fuel Tanks . . . . .	980 lbs	1010 lbs
BAGGAGE . . . . .	120 lbs	120 lbs
WING LOADING: Pounds/Sq Foot . . . . .	10.2	10.2
POWER LOADING: Pounds/HP . . . . .	16.0	16.0
FUEL CAPACITY:		
Total (Standard Tanks) . . . . .	26 gal.	26 gal.
Total (Long Range Tanks) . . . . .	38 gal.	38 gal.
OIL CAPACITY: (Total). . . . .	6 qts	6 qts
PROPELLER: Fixed Pitch (Diameter) . . . . .	69 inches	69 inches
ENGINE: Continental Engine. . . . .	O-200-A	O-200-A
100 rated HP at 2750 RPM		

\* This manual covers operation of the Model 150 which is certificated as Model 150J under FAA Type Certificate No. 3A19. The manual also covers operation of the Model F150 which is certificated as Model F150J under French Type Certificate No. 38/3 and FAA Type Certificate No. A13EU. The Model F150, manufactured by Reims Aviation S.A., Reims (Marne), France, is identical to the 150 except that it is powered by an O-200-A engine manufactured under license by Rolls Royce, Crewe, England. All 150 information in this manual pertains to the F150 as well.

# CONGRATULATIONS . . . . .

Welcome to the ranks of Cessna owners! Your Cessna has been designed and constructed to give you the most in performance, economy, and comfort. It is our desire that you will find flying it, either for business or pleasure, a pleasant and profitable experience.

This Owner's Manual has been prepared as a guide to help you get the most pleasure and utility from your Model 150. It contains information about your Cessna's equipment, operating procedures, and performance; and suggestions for its servicing and care. We urge you to read it from cover to cover, and to refer to it frequently.

Our interest in your flying pleasure has not ceased with your purchase of a Cessna. World-wide, the Cessna Dealer Organization backed by the Cessna Service Department stands ready to serve you. The following services are offered by most Cessna Dealers:

**FACTORY TRAINED PERSONNEL** to provide you with courteous expert service.

**FACTORY APPROVED SERVICE EQUIPMENT** to provide you with the most efficient and accurate workmanship possible.

**A STOCK OF GENUINE CESSNA SERVICE PARTS** on hand when you need them.

**THE LATEST AUTHORITATIVE INFORMATION FOR SERVICING CESSNA AIRPLANES**, since Cessna Dealers have all of the Service Manuals and Parts Catalogs, kept current by Service Letters and Service News Letters, published by Cessna Aircraft Company.

We urge all Cessna owners to use the Cessna Dealer Organization to the fullest.

A current Cessna Dealer Directory accompanies your new airplane. The Directory is revised frequently, and a current copy can be obtained from your Cessna Dealer. Make your Directory one of your cross-country flight planning aids; a warm welcome awaits you at every Cessna Dealer.

\* Maximum height of airplane with nose gear depressed and an optional flashing beacon installed.

\*\* Overall length of airplane with optional bullet-shaped propeller spinner. When standard propeller spinner is installed, length is 23'.

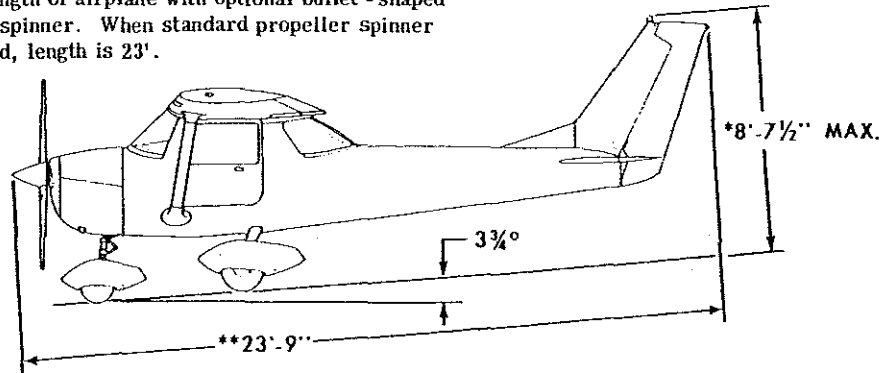

**PRINCIPAL  
DIMENSIONS**

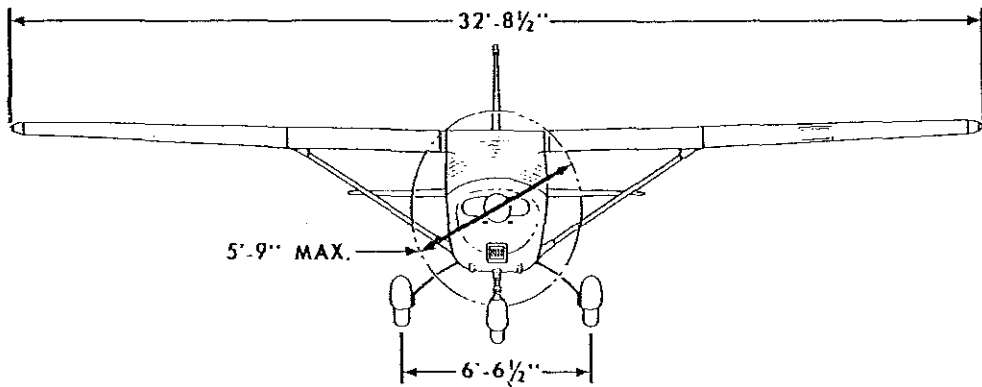
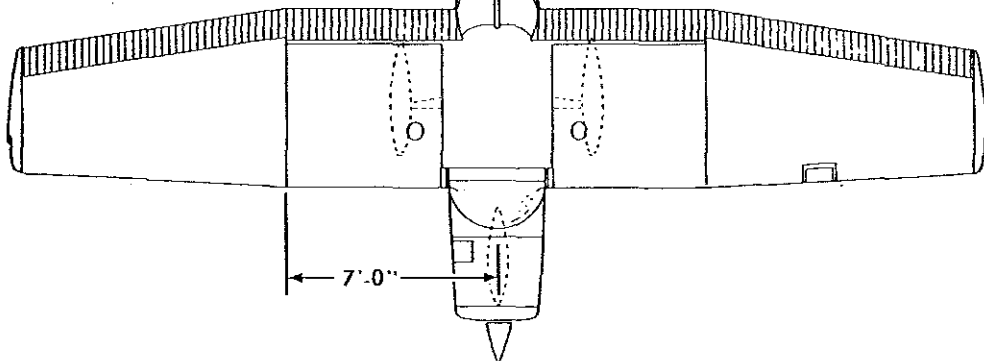
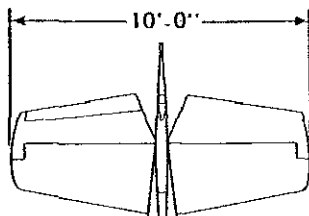

# TABLE OF CONTENTS

---

---

	Page
SECTION I - OPERATING CHECK LIST.....	1-1
SECTION II - DESCRIPTION AND OPERATING DETAILS .....	2-1
SECTION III - OPERATING LIMITATIONS.....	3-1
SECTION IV - CARE OF THE AIRPLANE .....	4-1
OWNER FOLLOW-UP SYSTEM .....	4-9
SECTION V - OPERATIONAL DATA .....	5-1
SECTION VI - OPTIONAL SYSTEMS .....	6-1
ALPHABETICAL INDEX .....	Index-1

---

This manual describes the operation and performance of the Standard Model 150, the Trainer and the Commuter. Equipment described as "Optional" denotes that the subject equipment is optional on the Standard airplane. Much of this equipment is standard on the Trainer and Commuter.

## EXTERIOR INSPECTION

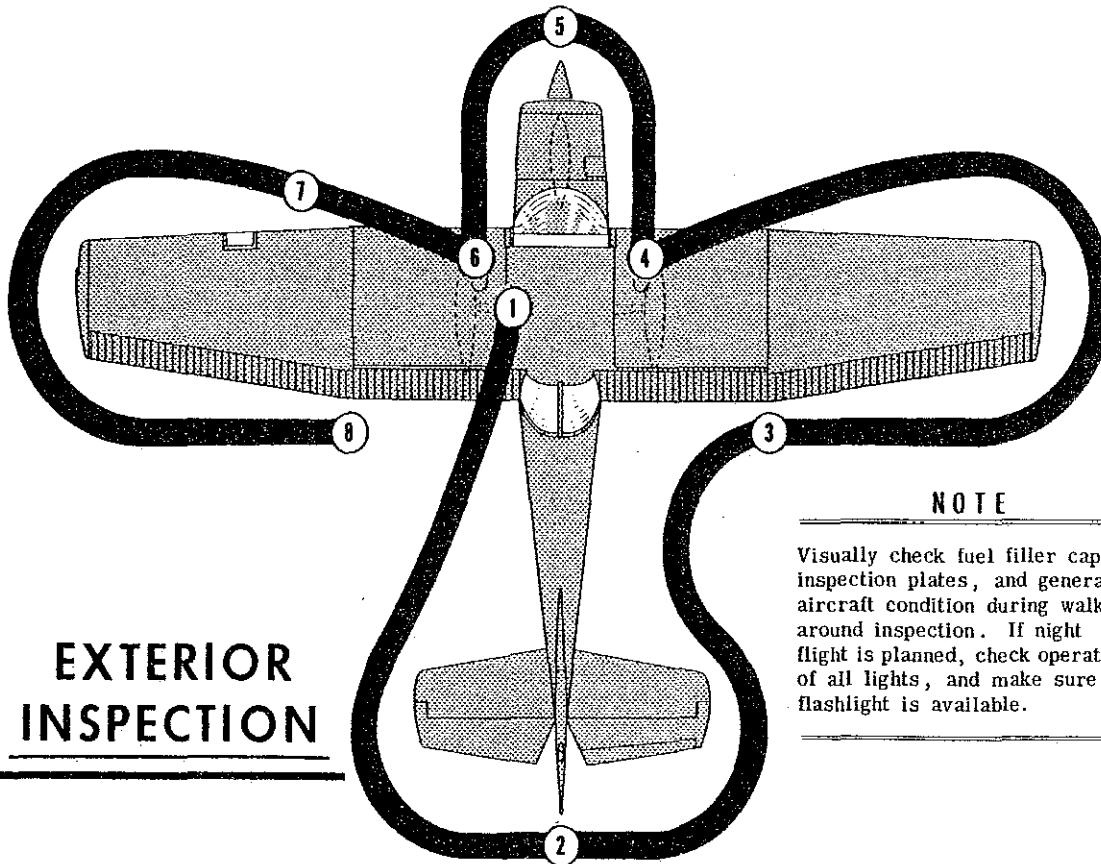

### NOTE

Visually check fuel filler caps, inspection plates, and general aircraft condition during walk-around inspection. If night flight is planned, check operation of all lights, and make sure a flashlight is available.

- 1 (a) Turn on master switch and check fuel quantity indicators, then turn master switch "OFF."  
 (b) Check ignition switch "OFF."  
 (c) Check fuel valve handle "ON."  
 (d) Remove control wheel lock.
- 2 (a) Remove rudder gust lock, if installed.  
 (b) Disconnect tail tie-down.
- 3 (a) Remove gust lock, if installed.
- 4 (a) Disconnect wing tie-down.  
 (b) Check main wheel tire for proper inflation.  
 (c) Inspect airspeed static source hole on side of fuselage for stoppage (left side only).
- 5 (a) Check oil level. Do not operate with less than 4 quarts. Fill for extended flights.  
 (b) Before first flight of day and after each refueling, pull out strainer drain knob for about four seconds to clear fuel strainer of possible water and sediment. Check strainer drain closed. If water is observed, there is a possibility that the wing tank sumps contain water. Thus, the wing tank sump drain plugs and fuel line drain plug should be removed to check for presence of water.
- 6 Same as 4
- 7 (a) Remove pitot tube cover, if installed, and check pitot tube opening for stoppage.  
 (b) Check fuel tank vent opening for stoppage.  
 (c) Check stall warning vent opening for stoppage.
- 8 Same as 3
- (c) Check propeller and spinner for nicks and security.  
 (d) Check carburetor air filter for restrictions by dust or other foreign matter.  
 (e) Check nosewheel strut and tire for proper inflation.  
 (f) Disconnect nose tie-down.

Figure 1-1.

# *Section I*

---

## OPERATING CHECK LIST

One of the first steps in obtaining the utmost performance, service, and flying enjoyment from your Cessna is to familiarize yourself with your airplane's equipment, systems, and controls. This can best be done by reviewing this equipment while sitting in the airplane. Those items whose function and operation are not obvious are covered in Section II.

Section I lists, in Pilot's Check List form, the steps necessary to operate your airplane efficiently and safely. It is not a check list in its true form as it is considerably longer, but it does cover briefly all of the points that you should know for a typical flight.

The flight and operational characteristics of your airplane are normal in all respects. There are no unconventional characteristics or operations that need to be mastered. All controls respond in the normal way within the entire range of operation. All airspeeds mentioned in Sections I and II are indicated airspeeds. Corresponding calibrated airspeeds may be obtained from the Airspeed Correction Table in Section V.

### **BEFORE ENTERING THE AIRPLANE.**

- (1) Make an exterior inspection in accordance with figure 1-1.

### **BEFORE STARTING THE ENGINE.**

- (1) Seats and Seat Belts -- Adjust and lock.
- (2) Fuel Valve Handle -- "ON."
- (3) Brakes -- Test and set.
- (4) Radios and Flashing Beacon -- "OFF."

### **STARTING THE ENGINE.**

- (1) Carburetor Heat -- Cold.
- (2) Mixture -- Rich.

- (3) Primer -- As required.
- (4) Throttle -- Open 1/4".
- (5) Master Switch -- "ON."
- (6) Propeller Area -- Clear.
- (7) Ignition Switch -- "START" (release when engine starts).
- (8) Oil Pressure -- Check.

## **BEFORE TAKE-OFF.**

- (1) Cabin Doors -- Latched.
- (2) Flight Controls -- Check.
- (3) Trim Tab -- "TAKE-OFF" setting.
- (4) Throttle Setting -- 1700 RPM.
- (5) Engine Instruments -- Within green arc.
- (6) Suction Gage -- Check (4.6 to 5.4 inches of mercury).
- (7) Carburetor Heat -- Check operation.
- (8) Magnetos -- Check (75 RPM maximum differential between magnetos.)
- (9) Flight Instruments and Radios -- Set.
- (10) Optional Wing Leveler -- "OFF."

## **TAKE-OFF.**

### **NORMAL TAKE-OFF.**

- (1) Wing Flaps -- Up.
- (2) Carburetor Heat -- Cold.
- (3) Throttle - Full "OPEN."
- (4) Elevator Control -- Lift nose wheel at 50 MPH.
- (5) Climb Speed -- 73 MPH until all obstacles are cleared, then set up climb speed as shown in "NORMAL CLIMB" paragraph.

### **MAXIMUM PERFORMANCE TAKE-OFF.**

- (1) Wing Flaps -- Up.
- (2) Carburetor Heat -- Cold.
- (3) Brakes -- Hold.
- (4) Throttle -- Full "OPEN."
- (5) Brakes -- Release.
- (6) Elevator Control -- Slightly tail low.
- (7) Climb Speed -- 64 MPH (with obstacles ahead).

## **CLIMB.**

### **NORMAL CLIMB.**

- (1) Air Speed -- 75 to 80 MPH.

- (2) Power -- Full throttle.
- (3) Mixture -- Rich (unless engine is rough).

#### **MAXIMUM PERFORMANCE CLIMB.**

- (1) Air Speed -- 73 MPH.
- (2) Power -- Full throttle.
- (3) Mixture -- Rich (unless engine is rough).

#### **CRUISING.**

- (1) Power -- 2000 to 2750 RPM.
- (2) Elevator Trim -- Adjust.
- (3) Mixture -- Lean to maximum RPM.

#### **BEFORE LANDING.**

- (1) Mixture -- Rich.
- (2) Carburetor Heat -- Apply full heat before closing throttle.
- (3) Airspeed -- 65 to 75 MPH.
- (4) Wing Flaps -- As desired below 100 MPH.
- (5) Airspeed -- 60 to 70 MPH (flaps extended).

#### **NORMAL LANDING.**

- (1) Touch Down -- Main wheels first.
- (2) Landing Roll -- Lower nose wheel gently.
- (3) Braking -- Minimum required.

#### **AFTER LANDING.**

- (1) Wing Flaps -- Up.
- (2) Carburetor Heat -- Cold.

#### **SECURE AIRCRAFT.**

- (1) Mixture -- Idle cut-off.
- (2) All Switches -- Off.
- (3) Parking Brake -- Set.
- (4) Control Lock -- Installed.

# INSTRUMENT PANEL

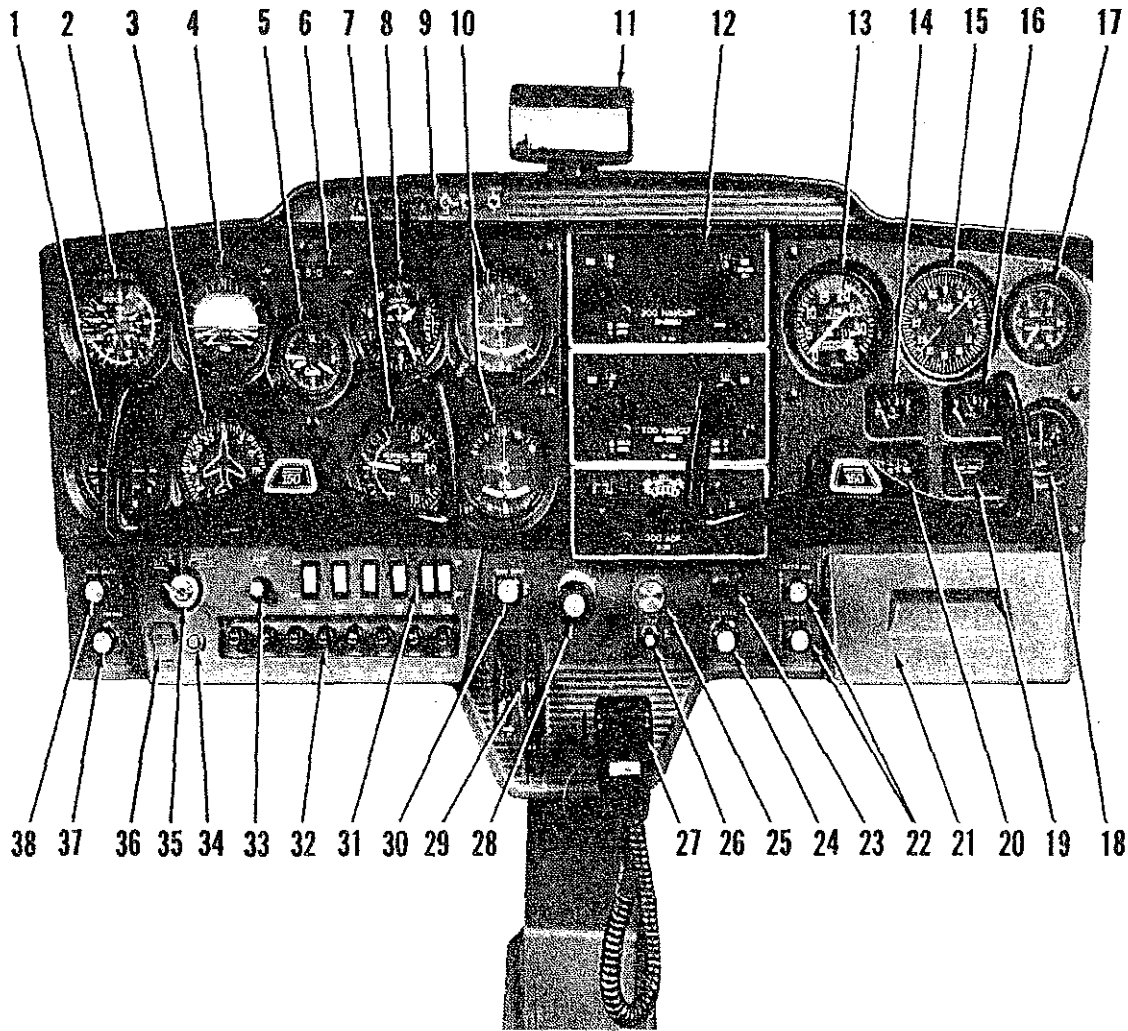

- |   |                                      |                                      |
|---|--------------------------------------|--------------------------------------|
| 1. Turn Coordinator (Opt.)                                | 13. Tachometer                       | 26. Wing Leveler Control Knob (Opt.) |
| 2. Airspeed Indicator                                     | 14. Left Fuel Quantity Indicator     | 27. Microphone (Opt.)                |
| 3. Directional Gyro (Opt.)                                | 15. Bearing Indicator (Opt.)         | 28. Throttle                         |
| 4. Gyro Horizon (Opt.)                                    | 16. Right Fuel Quantity Indicator    | 29. Elevator Trim Control Wheel      |
| 5. Clock (Opt.)   | 17. Suction Gage (Opt.)              | 30. Carburetor Heat Control Knob     |
| 6. Aircraft Registration Number                           | 18. Ammeter                          | 31. Electrical Switches              |
| 7. Vertical Speed Indicator (Opt.)                        | 19. Oil Temperature Gage             | 32. Fuses                            |
| 8. Altimeter  | 20. Oil Pressure Gage                | 33. Radio Dial Light Rheostat        |
| 9. Marker Beacon Lights/Radio Transmitter Selector Switch | 21. Map Compartment                  | 34. Alternator Circuit Breaker       |
| 10. Omni Course Indicator (Opt.)                          | 22. Cabin Air and Heat Control Knobs | 35. Ignition/Starter Switch          |
| 11. Rear View Mirror (Opt.)                               | 23. Wing Flap Switch                 | 36. Master Switch                    |
| 12. Radios (Opt.)   | 24. Cigar Lighter (Opt.)             | 37. Engine Primer                    |
|   | 25. Mixture Control Knob             | 38. Parking Brake Knob               |

Figure 2-1.

# Section II

## DESCRIPTION AND OPERATING DETAILS

The following paragraphs describe the systems and equipment whose function and operation is not obvious when sitting in the airplane. This section also covers in somewhat greater detail some of the items listed in Check List form in Section I that require further explanation.

### FUEL SYSTEM.

Fuel is supplied to the engine from two tanks, one in each wing. From these tanks, fuel flows by gravity through a fuel shutoff valve and fuel strainer to the carburetor.

Refer to figure 2-2 for fuel quantity data. For fuel system service information, refer to Lubrication and Servicing Procedures in Section IV.

### FUEL STRAINER DRAIN KNOB.

Refer to fuel strainer servicing procedure, Section IV.

### FUEL QUANTITY DATA (U.S. GALLONS)

TANKS	USABLE FUEL ALL FLIGHT CONDITIONS	UNUSABLE FUEL	TOTAL FUEL VOLUME
TWO, STANDARD WING (13 GAL. EACH)	22.5	3.5	26.0
TWO, LONG RANGE WING (19 GAL. EACH)	35.0	3.0	38.0

Figure 2-2.

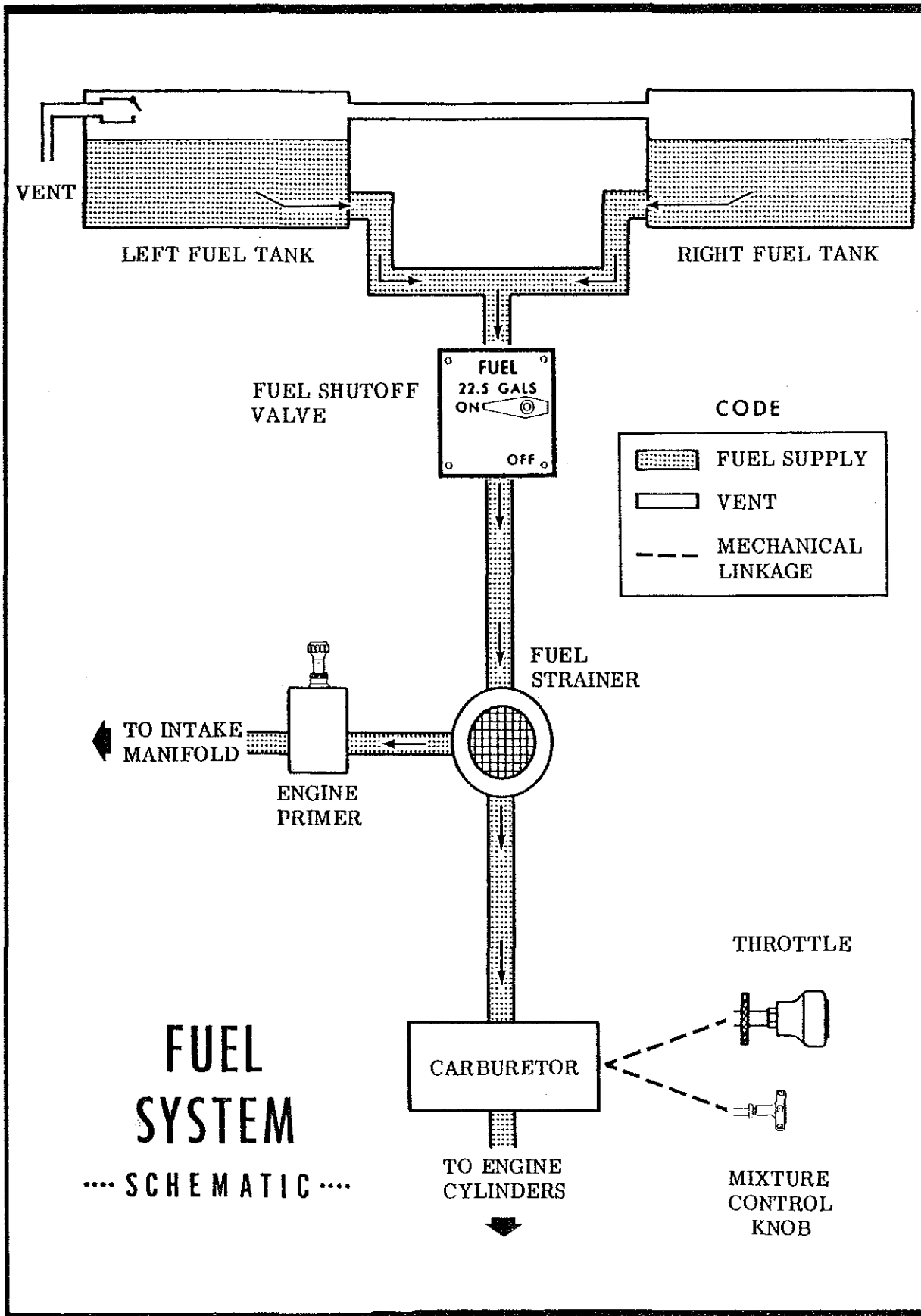

Figure 2-3.

## **ELECTRICAL SYSTEM.**

Electrical energy is supplied by a 14-volt, direct-current system powered by an engine-driven alternator (see figure 2-4). A 12-volt battery is located on the right, forward side of the firewall just inside the cowl access door. Power is supplied through a single bus bar; a master switch controls this power to all circuits, except the engine ignition system, optional clock and optional flight hour recorder (operative only when the engine is operating).

### **AMMETER.**

The ammeter indicates the flow of current, in amperes, from the alternator to the battery or from the battery to the aircraft electrical system. When the engine is operating and the master switch is "ON," the ammeter indicates the charging rate applied to the battery. In the event the alternator is not functioning or the electrical load exceeds the output of the alternator, the ammeter indicates the discharge rate of the battery.

### **FUSES AND CIRCUIT BREAKERS.**

Fuses on the left lower portion of the instrument panel protect the majority of electrical circuits in the airplane. Labeling below each fuse retainer indicates the circuits protected by the fuses. Fuse capacity is shown on each fuse retainer cap. Fuses are removed by pressing the fuse retainers inward and rotating them counterclockwise until they disengage. The faulty fuse may then be lifted out and replaced. Spare fuses are held in a clip on the inside of the map compartment door.

#### **NOTE**

A special "SLO-BLO" fuse protects the wing flaps circuit. If this fuse is replaced, care should be taken to assure that the replacement fuse is of the proper type and capacity. A "SLO-BLO" fuse is identified by an integrally mounted spring encircling the fuse element.

Two additional fuses are located adjacent to the battery; one fuse protects the battery contactor closing circuit, and the other fuse protects the optional clock and optional flight hour recorder circuits.

The airplane utilizes three circuit-breakers for circuit protection. A "push-to-reset" circuit breaker (labeled "GEN") is located on the left side of the instrument near the fuses and protects the alternator circuit. The

# ELECTRICAL SYSTEM SCHEMATIC

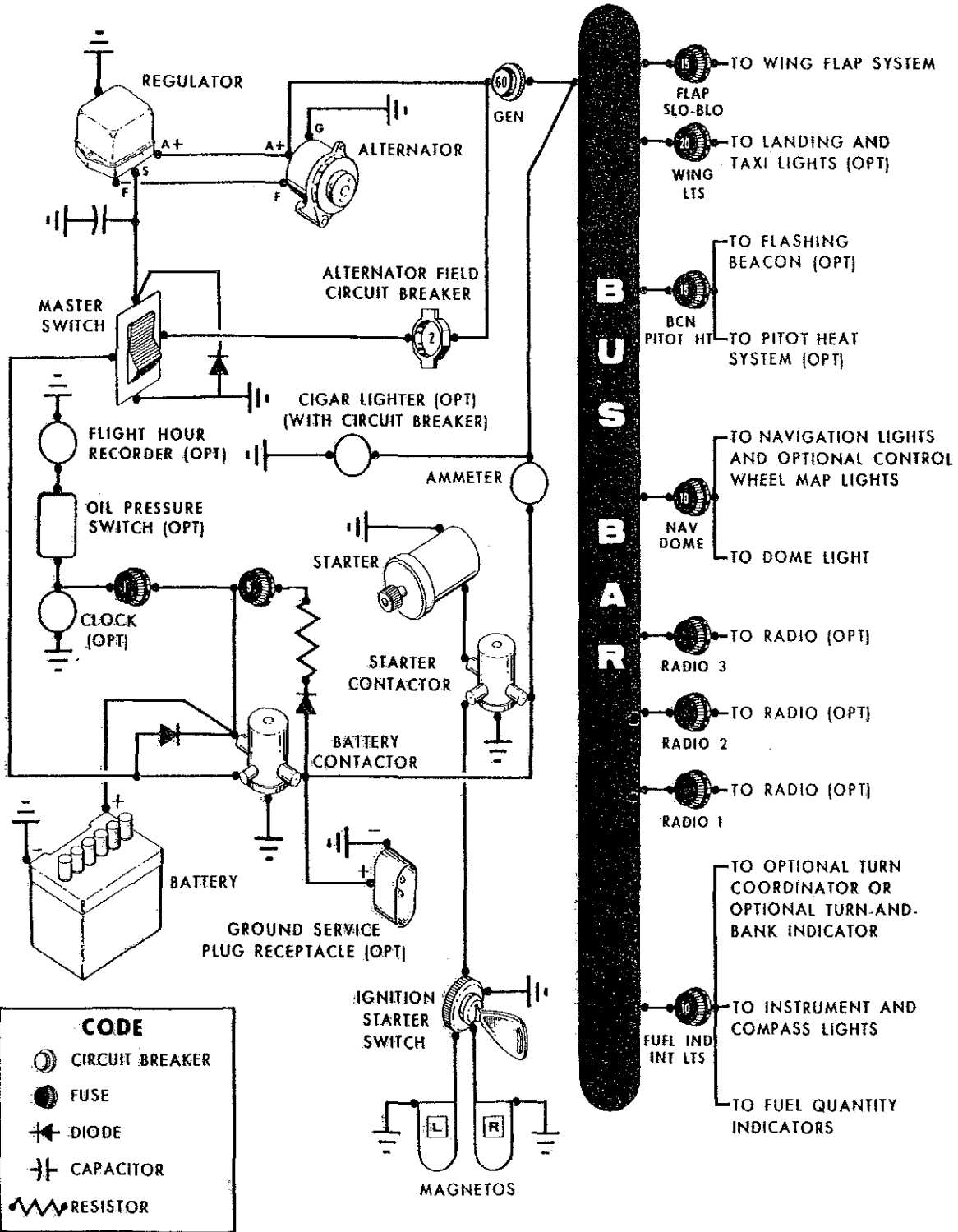

Figure 2-4.

alternator field and wiring is protected by an automatically resetting circuit breaker mounted behind the left side of the instrument panel. The cigar lighter has a manually reset type circuit breaker mounted directly on the back of the lighter behind the instrument panel.

### **CONTROL WHEEL MAP LIGHT (OPT).**

A map light may be mounted on the bottom of the pilot's control wheel. The light illuminates the lower portion of the cabin just forward of the pilot and is helpful when checking maps and other flight data during night operations. To operate the light, first turn on the "NAV LIGHTS" switch, then adjust the map light's intensity with the knurled rheostat knob located at the bottom of the control wheel.

### **FLASHING BEACON (OPT).**

The flashing beacon should not be used when flying through clouds or overcast; the flashing light reflected from water droplets or particles in the atmosphere, particularly at night, can produce vertigo and loss of orientation.

## **CABIN HEATING AND VENTILATING SYSTEM.**

The temperature and volume of airflow into the cabin can be regulated to any degree desired by manipulation of the push-pull "CABIN HEAT" and "CABIN AIR" knobs.

Heated fresh air and outside air are blended in a cabin manifold just aft of the firewall by adjustment of the heat and air controls; this air is then vented into the cabin from outlets in the cabin manifold near the pilot's and passenger's feet. Windshield defrost air is also supplied by a duct leading from the manifold.

A separate adjustable ventilator near each upper corner of the windshield supplies additional outside air to the pilot and passenger.

## **PARKING BRAKE SYSTEM.**

To set parking brake, pull out on the parking brake knob, apply and release toe pressure to the pedals, and then release the parking brake knob. To release the parking brake, apply and release toe pressure on the pedals while checking to see that the parking brake knob is full in.

# TAXIING DIAGRAM

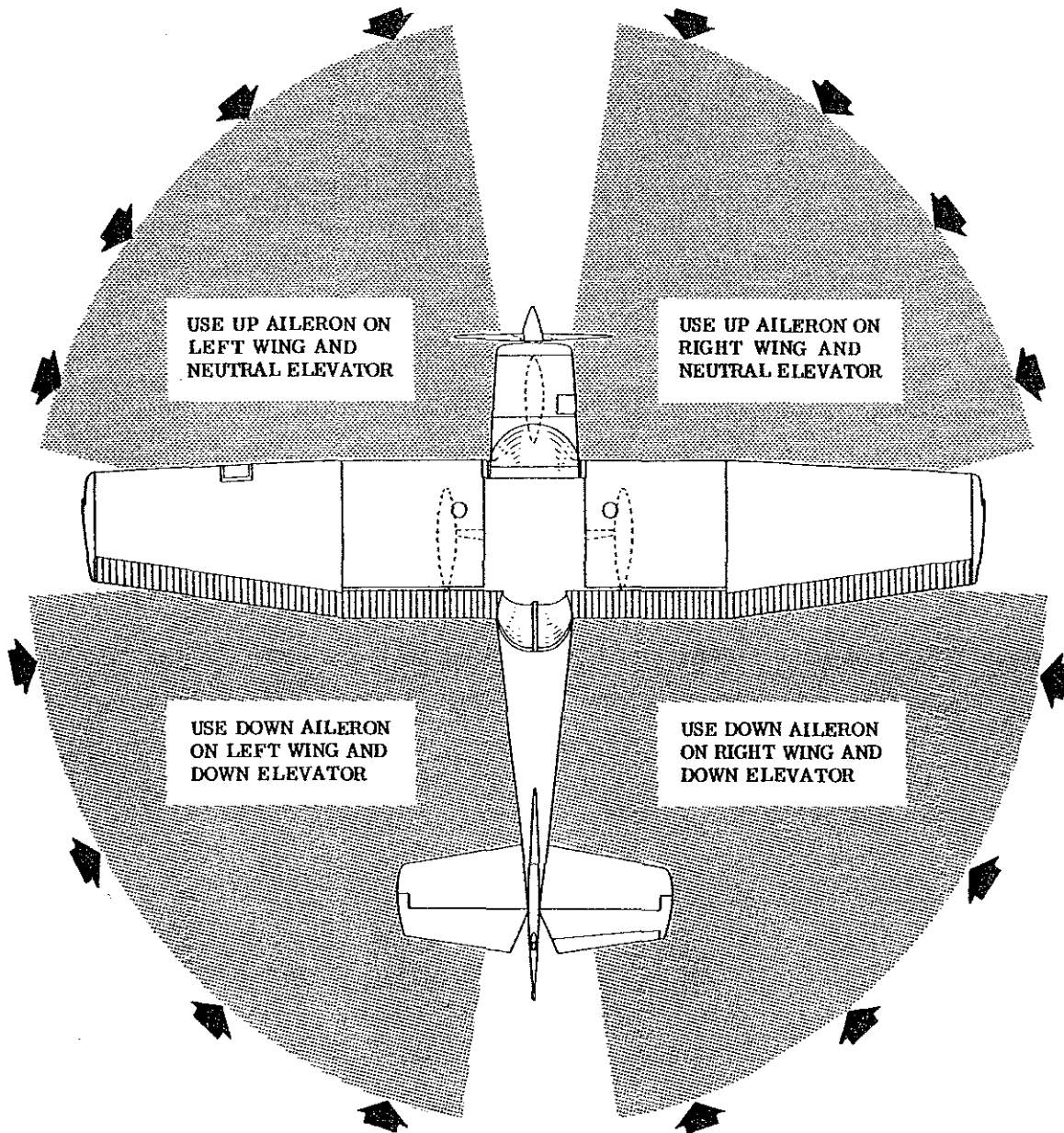

➔ WIND DIRECTION

## NOTE

.....  
Strong quartering tailwinds require caution. Avoid sudden bursts of the throttle and sharp braking when the airplane is in this attitude. Use the steerable nose wheel and rudder to maintain direction.

Figure 2-5.

## STARTING ENGINE.

Ordinarily the engine starts easily with one or two strokes of primer in warm temperatures to six strokes in cold weather, with the throttle open approximately 1/4 inch. In extremely cold temperatures, it may be necessary to continue priming while cranking.

Weak intermittent explosions followed by puffs of black smoke from the exhaust stack indicate overpriming or flooding. Excess fuel can be cleared from the combustion chambers by the following procedure: Set the mixture control in full lean position, throttle full open, and crank the engine through several revolutions with the starter. Repeat the starting procedure without any additional priming.

If the engine is underprimed (most likely in cold weather with a cold engine) it will not fire at all, and additional priming will be necessary. As soon as the cylinders begin to fire, open the throttle slightly to keep it running.

After starting, if the oil gage does not begin to show pressure within 30 seconds in the summertime and about twice that long in very cold weather, stop engine and investigate. Lack of oil pressure can cause serious engine damage. After starting, avoid the use of carburetor heat unless icing conditions prevail.

## TAXIING.

When taxiing, it is important that speed and use of brakes be held to a minimum and that all controls be utilized (see taxiing diagram, figure 2-5) to maintain directional control and balance.

Taxiing over loose gravel or cinders should be done at low engine speed to avoid abrasion and stone damage to the propeller tips.

The nose wheel is designed to automatically center straight ahead when the nose strut is fully extended. In the event the nose strut is over-inflated and the airplane is loaded to a rearward center of gravity position, it may be necessary to partially compress the strut to permit steering. This can be accomplished prior to taxiing by depressing the airplane nose (by hand) or during taxi by sharply applying brakes.

## **BEFORE TAKE-OFF.**

### **WARM-UP.**

Most of the warm-up will have been conducted during taxi, and additional warm-up before take-off should be restricted to the checks outlined in Section I. Since the engine is closely cowled for efficient in-flight cooling, precautions should be taken to avoid overheating on the ground.

### **MAGNETO CHECK.**

The magneto check should be made at 1700 RPM as follows: Move the ignition switch first to "R" position and note RPM. Then move switch back to "BOTH" position to clear the other set of plugs. Then move switch to "L" position and note RPM. The difference between the two magnetos operated individually should not be more than 75 RPM. If there is a doubt concerning the operation of the ignition system, RPM checks at higher engine speeds will usually confirm whether a deficiency exists.

An absence of RPM drop may be an indication of faulty grounding of one side of the ignition system or should be cause for suspicion that the magneto timing is set in advance of the setting specified.

## **TAKE-OFF.**

### **POWER CHECKS.**

It is important to check full-throttle engine operation early in the take-off run. Any signs of rough engine operation or sluggish engine acceleration is good cause for discontinuing the take-off. If this occurs, you are justified in making a thorough full-throttle, static runup before another take-off is attempted. The engine should run smoothly and turn approximately 2500 to 2600 RPM with carburetor heat off.

Full throttle runups over loose gravel are especially harmful to propeller tips. When take-offs must be made over a gravel surface, it is very important that the throttle be advanced slowly. This allows the airplane to start rolling before high RPM is developed, and the gravel will be blown back of the propeller rather than pulled into it. When unavoid-

able small dents appear in the propeller blades, they should be immediately corrected as described in Section IV.

Prior to take-off from fields above 5000 feet elevation, the mixture should be leaned to give maximum RPM in a full-throttle, static runup.

## **FLAP SETTINGS.**

Normal and obstacle clearance take-offs are performed with flaps up. The use of 10° flaps will shorten the ground run approximately 10%, but this advantage is lost in the climb to a 50-foot obstacle. Therefore the use of 10° flap is reserved for minimum ground runs or for take-off from soft or rough fields with no obstacles ahead.

If 10° of flaps are used in ground runs, it is preferable to leave them extended rather than retract them in the climb to the obstacle. The exception to this rule would be in a high altitude take-off in hot weather where climb would be marginal with flaps 10°.

Flap deflections of 30° and 40° are not recommended at any time for take-off.

## **PERFORMANCE CHARTS.**

Consult the Take-Off Distance chart in Section V for take-off distances at gross weight under various altitude and headwind conditions.

## **CROSSWIND TAKE-OFFS.**

Take-offs into strong crosswinds normally are performed with the minimum flap setting necessary for the field length, to minimize the drift angle immediately after take-off. The airplane is accelerated to a speed slightly higher than normal, then pulled off abruptly to prevent possible settling back to the runway while drifting. When clear of the ground, make a coordinated turn into the wind to correct for drift.

## **CLIMB.**

### **CLIMB DATA.**

For detailed data, see Maximum Rate-of-Climb Data chart in Section V.

## CLIMB SPEEDS.

Normal climbs are conducted at 75 to 80 MPH with flaps up and full throttle, for best engine cooling. The mixture should be full rich unless the engine is rough due to too rich a mixture. The best rate-of-climb speeds range from 73 MPH at sea level to 65 MPH at 10,000 feet. If an obstruction dictates the use of a steep climb angle, climb at 64 MPH with flaps retracted.

### NOTE

Steep climbs at these low speeds should be of short duration to allow improved engine cooling.

## GO-AROUND CLIMB.

In a balked landing (go-around) climb, the wing flap setting should be reduced to 20° immediately after full power is applied. Upon reaching a safe airspeed, the flaps should be slowly retracted to the full up position.

## CRUISE.

Normal cruising is done between 65% and 75% power. The power settings required to obtain these powers at various altitudes and outside air temperatures can be determined by using your Cessna Power Computer or the OPERATIONAL DATA, Section V.

Cruising can be done most efficiently at high altitude because of lower air density and therefore higher true airspeeds for the same power. This is illustrated in the following table which shows performance at 75% power at various altitudes.

### OPTIMUM CRUISE PERFORMANCE

ALTITUDE	RPM	TRUE AIRSPEED
Sea Level	* 2525	110
5000 feet	* 2650	115
7000 feet	* Full Throttle	117

\* 75% POWER

All figures in the Optimum Cruise Performance table are based on lean mixture, 22.5 gallons of fuel (no reserve), zero wind, standard atmospheric conditions, and 1600 pounds gross weight.

To achieve the lean mixture fuel consumption figures shown in Section V, the mixture should be leaned as follows: pull the mixture control out until engine RPM peaks and begins to fall off, then enrichen slightly back to peak RPM.

Carburetor ice, as evidenced by an unexplained drop in RPM, can be removed by application of full carburetor heat. Upon regaining the original RPM (with heat off), use the minimum amount of heat (by trial and error) to prevent ice from forming. Since the heated air causes a richer mixture, readjust the mixture setting when carburetor heat is to be used continuously in cruise flight.

The use of full carburetor heat is recommended during flight in very heavy rain to avoid the possibility of engine stoppage due to excessive water ingestion. The mixture setting should be readjusted for smoothest operation.

## **STALLS.**

The stall characteristics are conventional for the flaps up and flaps down condition. Slight elevator buffeting may occur just before the stall with flaps down.

Stalling speeds are shown in Section V for aft c.g., full gross weight conditions. They are presented as calibrated airspeeds because indicated airspeeds are unreliable near the stall. The stall warning horn produces a steady signal 5 to 10 MPH before the actual stall is reached and remains on until the airplane flight attitude is changed.

## **LANDING.**

Normal landings are made power off with any flap setting. Approach glides are normally made at 65 to 75 MPH with flaps up, or 60 to 70 MPH with flaps down, depending upon the turbulence of the air.

## **SHORT FIELD LANDINGS.**

For short field landings, make a power-off approach at 58 MPH with

flaps 40° and land on the main wheels first. Immediately after touchdown, lower the nose gear to the ground and apply heavy braking as required. For maximum brake effectiveness after all three wheels are on the ground, retract the flaps, hold full nose up elevator, and apply maximum possible brake pressure without sliding the tires.

## CROSSWIND LANDINGS.

When landing in a strong crosswind, use the minimum flap setting required for the field length. Use a wing low, crab, or a combination method of drift correction and land in a nearly level attitude.

Excessive nose strut inflation can hinder nose wheel alignment with the airplane ground track in a drifting crosswind landing at touchdown and during ground roll. This can be counteracted by firmly lowering the nose wheel to the ground after initial contact. This action partially compresses the nose strut, permitting nose wheel swiveling and positive ground steering.

## COLD WEATHER OPERATION.

Prior to starting on cold mornings, it is advisable to pull the propeller through several times by hand to "break loose" or "limber" the oil, thus conserving battery energy. In extremely cold (0° F and lower) weather the use of an external preheater is recommended whenever possible to reduce wear and abuse to the engine and the electrical system.

Cold weather starting procedures are as follows:

### With Preheat:

- (1) With ignition switch "OFF" and throttle closed, prime the engine four to ten strokes as the propeller is being turned over by hand.

### NOTE

Use heavy strokes of primer for best atomization of fuel. After priming, push primer all the way in and turn to locked position to avoid possibility of engine drawing fuel through the primer.

- (2) Propeller Area -- Clear.
- (3) Master Switch -- "ON."
- (4) Throttle -- Open 1/4".
- (5) Ignition Switch -- "START."
- (6) Release ignition switch to "BOTH" when engine starts.
- (7) Oil Pressure -- Check.

Without Preheat:

- (1) Prime the engine eight to ten strokes while the propeller is being turned by hand with throttle closed. Leave primer charged and ready for stroke.
- (2) Propeller Area -- Clear.
- (3) Master Switch -- "ON."
- (4) Pump throttle rapidly to full open twice. Return to 1/4" open position.
- (5) Ignition Switch -- "START."
- (6) Release ignition switch to "BOTH" when engine starts.
- (7) Continue to prime engine until it is running smoothly, or alternately, pump throttle rapidly over first 1/4 of total travel.
- (8) Oil Pressure -- Check.
- (9) Pull carburetor heat knob full on after engine has started. Leave on until engine is running smoothly.
- (10) Lock primer.

NOTE

If the engine does not start during the first few attempts, or if the engine firing diminishes in strength, it is probable that the spark plugs have been frosted over. Preheat must be used before another start is attempted.

IMPORTANT

Pumping the throttle may cause raw fuel to accumulate in the intake air duct, creating a fire hazard in the event of a backfire. If this occurs, maintain a cranking action to suck flames into the engine. An outside attendant with a fire extinguisher is advised for cold starts without pre-heat.

During cold weather operations, no indication will be apparent on the oil temperature gage prior to take-off if outside air temperatures are very cold. After a suitable warm-up period (2 to 5 minutes at 1000 RPM), ac-

celerate the engine several times to higher engine RPM. If the engine accelerates smoothly and the oil pressure remains normal and steady, the airplane is ready for take-off.

When operating in sub-zero temperature, avoid using partial carburetor heat. Partial heat may increase the carburetor air temperature to the 32° to 70° range, where icing is critical under certain atmospheric conditions.

Refer to Section VI for cold weather equipment.

# Section III

## OPERATING LIMITATIONS

### OPERATIONS AUTHORIZED.

Your Cessna exceeds the requirements of airworthiness as set forth by the United States Government, and is certificated under FAA Type Certificate No. 3A19 as Cessna Model No. 150J.

With standard equipment, the airplane is approved for day and night operation under VFR. Additional optional equipment is available to increase its utility and to make it authorized for use under IFR day and night.

Your airplane must be operated in accordance with all FAA-approved markings, placards and check lists in the airplane. If there is any information in this section which contradicts the FAA-approved markings, placards and check lists, it is to be disregarded.

### MANEUVERS-UTILITY CATEGORY.

This airplane is not designed for purely aerobatic flight. However, in the acquisition of various certificates such as commercial pilot, instrument pilot and flight instructor, certain maneuvers are required by the FAA. All of these maneuvers are permitted in this airplane when operated in the utility category. In connection with the foregoing, the following gross weight and flight load factors apply, with maximum entry speeds for maneuvers as shown:

Gross Weight . . . . .	1600 lbs
Flight Maneuvering Load Factor, *Flaps Up . . .	+4.4    -1.76
Flight Maneuvering Load Factor, *Flaps Down . .	+3.5

\*The design load factors are 150% of the above, and in all cases, the structure meets or exceeds design loads.

No aerobatic maneuvers are approved except those listed below:

<u>MANEUVER</u>	<u>MAXIMUM ENTRY SPEED</u>
Chandelles . . . . .	109 MPH (95 knots)
Lazy Eights . . . . .	109 MPH (95 knots)
Steep Turns . . . . .	109 MPH (95 knots)
Spins . . . . .	Use Slow Deceleration
Stalls (Except Whip Stalls) . . . . .	Use Slow Deceleration

During prolonged spins, the aircraft engine may stop; however, spin recovery is not adversely affected by engine stoppage. Intentional spins with wing flaps extended are prohibited.

Aerobatics that may impose high inverted loads should not be attempted. The important thing to bear in mind in flight maneuvers is that the airplane is clean in aerodynamic design and will build up speed quickly with the nose down. Proper speed control is an essential requirement for execution of any maneuver, and care should always be exercised to avoid excessive speed which in turn can impose excessive loads. In the execution of all maneuvers, avoid abrupt use of controls.

## AIRSPEED LIMITATIONS (CAS).

The following is a list of the certificated calibrated airspeed (CAS) limitations for the airplane.

Never Exceed Speed (glide or dive, smooth air) . . . . .	162 MPH
Maximum Structural Cruising Speed . . . . .	120 MPH
Maximum Speed, Flaps Extended . . . . .	100 MPH
*Maximum Maneuvering Speed . . . . .	109 MPH

\*The maximum speed at which abrupt control travel can be used without exceeding the design load factor.

## AIRSPEED INDICATOR MARKINGS.

The following is a list of the certificated calibrated airspeed markings (CAS) for the airplane.

Never Exceed (glide or dive, smooth air) . . . . .	162 MPH (red line)
Caution Range . . . . .	120-162 MPH (yellow arc)
Normal Operating Range . . . . .	56-120 MPH (green arc)
Flap Operating Range . . . . .	49-100 MPH (white arc)

## ENGINE OPERATION LIMITATIONS.

Power and Speed . . . . . 100 BHP at 2750 RPM

## ENGINE INSTRUMENT MARKINGS.

### OIL TEMPERATURE GAGE.

Normal Operating Range . . . . . Green Arc  
Maximum Allowable . . . . . 225° F Red Line

### OIL PRESSURE GAGE.

Minimum Idling . . . . . 10 PSI (red line)  
Normal Operating Range . . . . . 30-60 PSI (green arc)  
Maximum . . . . . 100 PSI (red line)

### FUEL QUANTITY INDICATORS.

Empty (1.75 gallons unusable each standard tank) . . . E (red line)  
(1.50 gallons unusable each long range tank)

### TACHOMETER.

Normal Operating Range: -  
At sea level . . . . . 2000-2550 (inner green arc)  
At 5000 feet . . . . . 2000-2650 (middle green arc)  
At 10,000 feet . . . . . 2000-2750 (outer green arc)  
Maximum Allowable . . . . . 2750 (red line)

## WEIGHT AND BALANCE.

The following information will enable you to operate your Cessna within the prescribed weight and center of gravity limitations. To figure the weight and balance for your particular airplane, use the Sample Problem, Loading Graph, and Center of Gravity Moment Envelope as follows:

Take the licensed Empty Weight and Moment/1000 from the Weight and Balance Data sheet, plus any changes noted on forms FAA-337, carried in your airplane, and write them down in the proper columns. Using the Loading Graph, determine the moment/1000 of each item to be

carried. Total the weights and moments/1000 and use the Center of Gravity Moment Envelope to determine whether the point falls within the envelope, and if the loading is acceptable.

#### NOTE

The Weight and Balance Data sheet noted above is included in the aircraft file. The Loading Graph and Center of Gravity Moment Envelope shown in this section are also on the sheet titled Loading/Center of Gravity Charts and Weighing Procedure which is provided in the aircraft file.

SAMPLE LOADING PROBLEM	SAMPLE AIRPLANE		YOUR AIRPLANE	
	Weight (lbs.)	Moment (lb.-ins./1000)	Weight (lbs.)	Moment (lb.-ins./1000)
1. Licensed Empty Weight (Sample Airplane) . . .	1038	34.1	1108.9	33.7
2. Oil (6 qts. - Full oil may be assumed for all flights) . . . . .	11	-0.1	11	-0.1
3. Fuel (Standard - 22.5 gal at 6 lbs./gallon) . . .	135	5.7	135	5.7
Fuel (Long Range - 35 gal. at 6 lbs./gallon) . .				
4. Pilot and Passenger . . . . .	340	13.3		
5. Baggage - Area 1 (or children on child's seat) . . . . .	(34.5 kg) 76	4.9	44.1	2.6
6. Baggage - Area 2 . . . . .	0	0.0		
7. TOTAL WEIGHT AND MOMENT	1600	57.9		
8. Locate this point (1600 at 57.9) on the center of gravity moment envelope, and since this point falls within the envelope, the loading is acceptable.				

400 Pounds = 181.5 kg      moment 15.5  
 441 ~ 196 = 200 kg

## BAGGAGE LOADING AND TIE-DOWN

UTILITY SHELF

**BAGGAGE AREA  
MAXIMUM ALLOWABLE LOADS**

---

AREA ① = 120 POUNDS  
 AREA ② = 40 POUNDS  
 AREAS ① + ② = 120 POUNDS

**\* TIE-DOWN NET ATTACH POINTS**

\* A cargo tie-down net is provided to secure baggage in the baggage area. The net attaches to six tie-down rings. Two rings are located on the floor just aft of the seat backs and one ring is located two inches above the floor on each cabin wall at the aft end of area ①. Two additional rings are located at the top, aft end of area ②. At least four rings should be used to restrain the maximum baggage load of 120#.

---

If the airplane is equipped with an optional utility shelf, it should be removed prior to loading and tying down large baggage items. (Slide the tab of the locking clips on each end of the shelf to disengage the shelf from the aircraft structure.) After baggage is loaded and secured, either stow the shelf or, if space permits, install it for storing small articles.

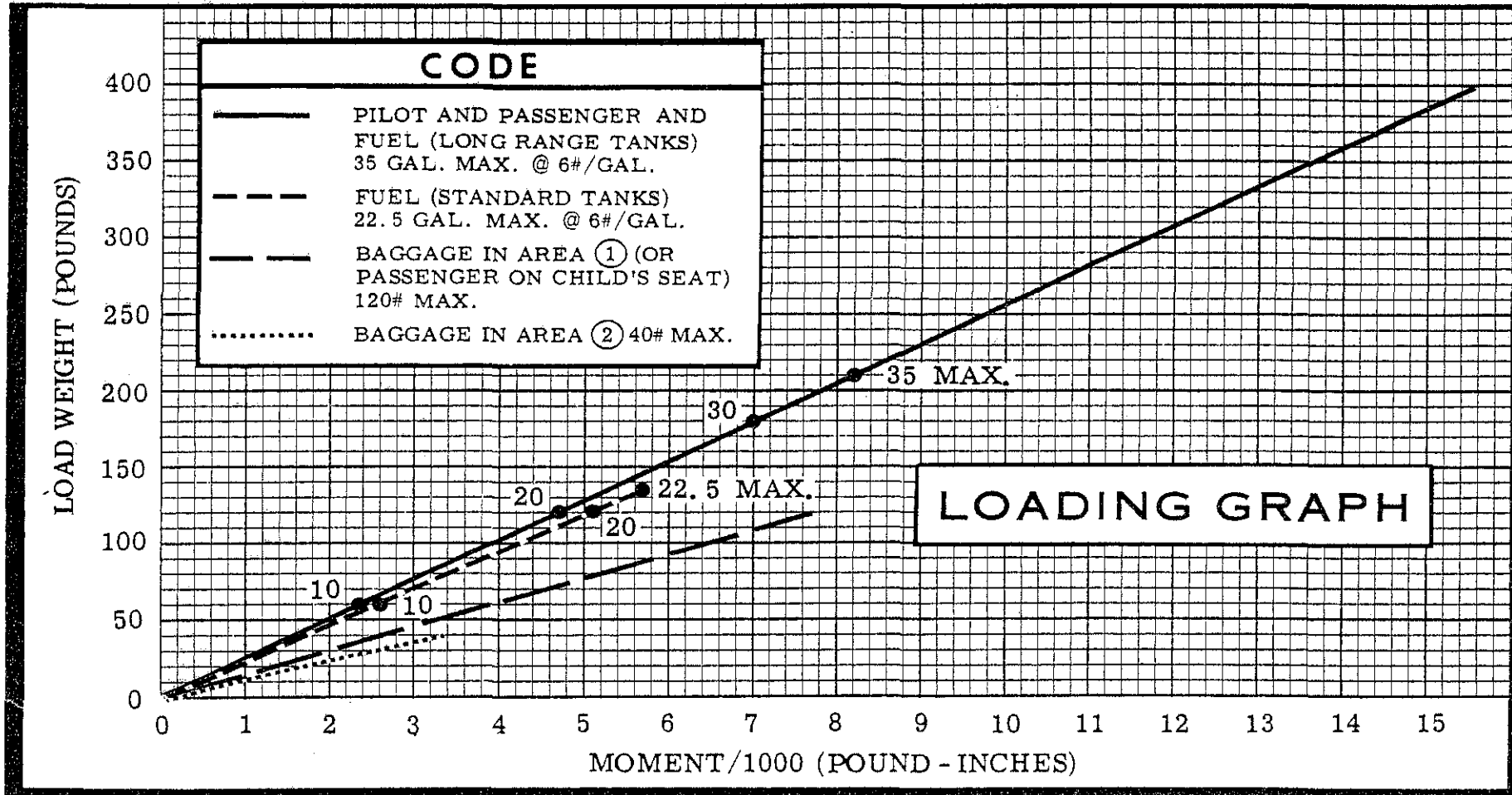

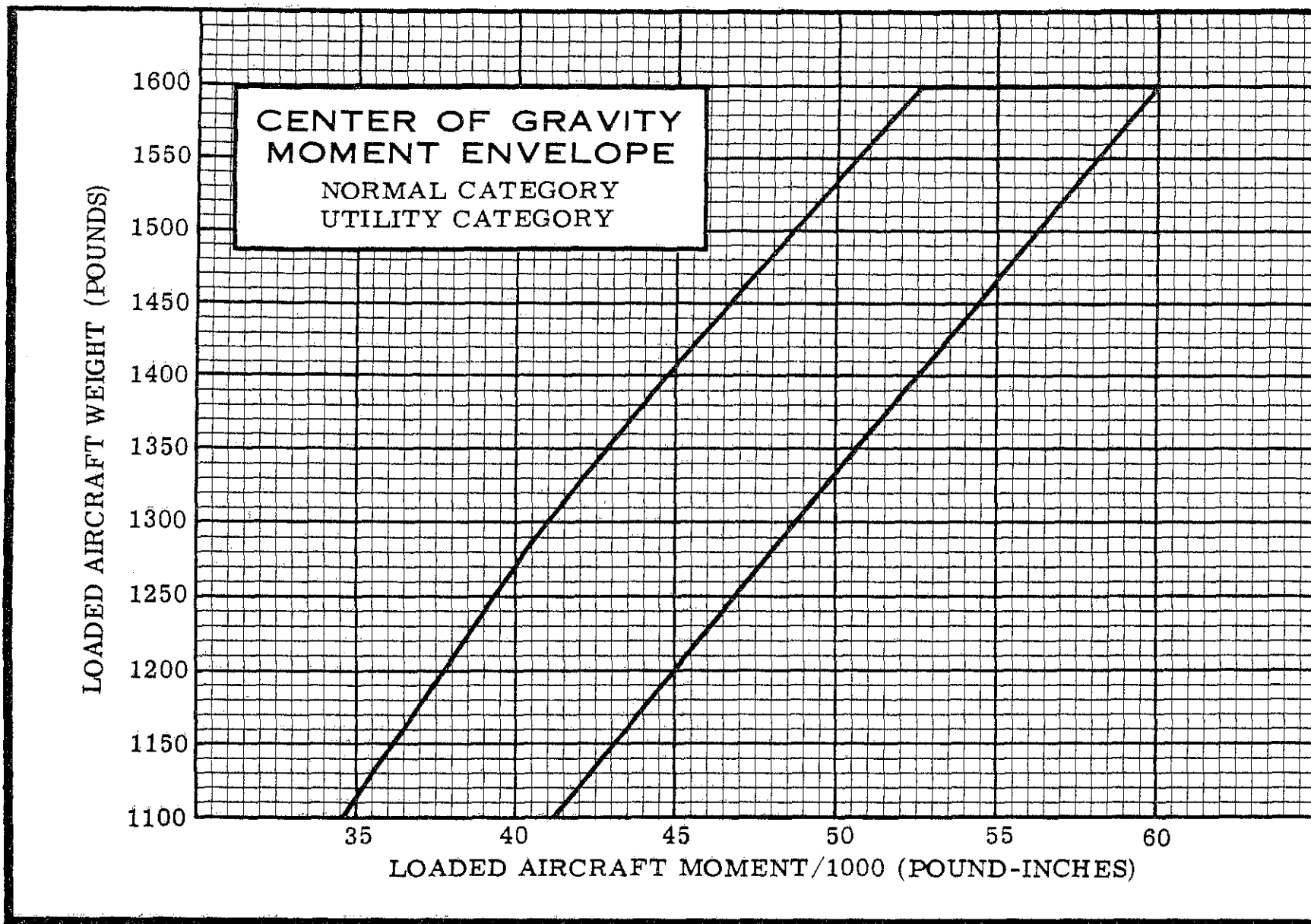

# *Section IV*

---

## CARE OF THE AIRPLANE

If your airplane is to retain that new-plane performance, stamina, and dependability, certain inspection and maintenance requirements must be followed. It is always wise to follow a planned schedule of lubrication and maintenance based on the climatic and flying conditions encountered in your locality.

Keep in touch with your Cessna dealer, and take advantage of his knowledge and experience. He knows your airplane and how to maintain it. He will remind you when lubrications and oil changes are necessary and about other seasonal and periodic services.

### GROUND HANDLING.

The airplane is most easily and safely maneuvered by hand with a tow-bar attached to the nose wheel.

#### NOTE

When using the tow-bar, never exceed the turning angle of 30°, either side of center, or damage to the gear will result.

### MOORING YOUR AIRPLANE.

Proper tie-down is the best precaution against damage to your parked airplane by gusty or strong winds. To tie down your airplane securely, proceed as follows:

- (1) Set parking brake and install control wheel lock.
- (2) Install a surface control lock between each aileron and flap.
- (3) Tie sufficiently strong ropes or chains (700 pounds tensile strength) to wing and tail tie-down fittings, and secure each rope

to ramp tie-down.

- (4) Install a surface control lock over the fin and rudder.
- (5) Install a pitot tube cover.
- (6) Tie a rope to an exposed portion of the engine mount and secure the opposite end to a ramp tie-down.

## WINDSHIELD-WINDOWS.

The plastic windshield and windows should be cleaned with an aircraft windshield cleaner. Apply the cleaner sparingly with soft cloths, and rub with moderate pressure until all dirt, oil scum and bug stains are removed. Allow the cleaner to dry, then wipe it off with soft flannel cloths.

If a windshield cleaner is not available, the plastic can be cleaned with soft cloths moistened with Stoddard solvent to remove oil and grease.

### NOTE

Never use gasoline, benzine, alcohol, acetone, carbon tetrachloride, fire extinguisher or anti-ice fluid, lacquer thinner or glass cleaner to clean the plastic. These materials will attack the plastic and may cause it to craze.

Follow by carefully washing with a mild detergent and plenty of water. Rinse thoroughly, then dry with a clean moist chamois. Do not rub the plastic with a dry cloth since this builds up an electrostatic charge which attracts dust. Waxing with a good commercial wax will finish the cleaning job. A thin, even coat of wax, polished out by hand with clean soft flannel cloths, will fill in minor scratches and help prevent further scratching.

Do not use a canvas cover on the windshield unless freezing rain or sleet is anticipated since the cover may scratch the plastic surface.

## PAINTED SURFACES.

The painted exterior surfaces of your new Cessna have a durable, long lasting finish and, under normal conditions, require no polishing or buffing. Approximately 15 days are required for the paint to cure completely; in most cases, the curing period will have been completed prior to delivery of the airplane. In the event that polishing or buffing is required within the curing period, it is recommended that the work be done

by someone experienced in handling uncured paint. Any Cessna Dealer can accomplish this work.

Generally, the painted surfaces can be kept bright by washing with water and mild soap, followed by a rinse with water and drying with cloths or a chamois. Harsh or abrasive soaps or detergents which cause corrosion or make scratches should never be used. Remove stubborn oil and grease with a cloth moistened with Stoddard solvent.

Waxing is unnecessary to keep the painted surfaces bright. However, if desired, the airplane may be waxed with a good automotive wax. A heavier coating of wax on the leading edges of the wings and tail and on the engine nose cap and propeller spinner will help reduce the abrasion encountered in these areas.

When the airplane is parked outside in cold climates and it is necessary to remove ice before flight, care should be taken to protect the painted surfaces during ice removal with chemical liquids. A 50-50 solution of isopropyl alcohol and water will satisfactorily remove ice accumulations without damaging the paint. A solution with more than 50% alcohol is harmful and should be avoided. While applying the de-icing solution, keep it away from the windshield and cabin side windows since the alcohol will attack the plastic and may cause it to craze.

## **ALUMINUM SURFACES.**

The clad aluminum surfaces of your Cessna require only minimum care to keep them bright and clean. The airplane may be washed with water to remove dirt; oil and grease may be removed with gasoline, naphtha, carbon tetrachloride or other non-alkaline solvents. Dulled aluminum surfaces may be cleaned effectively with an aircraft aluminum polish.

After cleaning, and periodically thereafter, waxing with a good automotive wax will preserve the bright appearance and retard corrosion. Regular waxing is especially recommended for airplanes operated in salt water areas as a protection against corrosion.

## **PROPELLER CARE.**

Preflight inspection of propeller blades for nicks, and wiping them

occasionally with an oily cloth to clean off grass and bug stains will assure long, trouble-free service. It is vital that small nicks on the blades, particularly near the tips and on the leading edges, are dressed out as soon as possible since these nicks produce stress concentrations, and if ignored, may result in cracks. Never use an alkaline cleaner on the blades; remove grease and dirt with carbon tetrachloride or Stoddard solvent.

## **INTERIOR CARE.**

To remove dust and loose dirt from the upholstery, headliner, and carpet, clean the interior regularly with a vacuum cleaner.

Blot up any spilled liquid promptly, with cleansing tissue or rags. Don't pat the spot; press the blotting material firmly and hold it for several seconds. Continue blotting until no more liquid is taken up. Scrape off sticky materials with a dull knife, then spot-clean the area.

Oily spots may be cleaned with household spot removers, used sparingly. Before using any solvent, read the instructions on the container and test it on an obscure place on the fabric to be cleaned. Never saturate the fabric with a volatile solvent; it may damage the padding and backing materials.

Soiled upholstery and carpet may be cleaned with foam-type detergent, used according to the manufacturer's instructions. To minimize wetting the fabric, keep the foam as dry as possible and remove it with a vacuum cleaner.

The plastic trim, instrument panel and control knobs need only be wiped off with a damp cloth. Oil and grease on the control wheel and control knobs can be removed with a cloth moistened with kerosene. Volatile solvents, such as mentioned in paragraphs on care of the windshield, must never be used since they soften and craze the plastic.

## **INSPECTION SERVICE AND INSPECTION PERIODS.**

With your airplane you will receive an Owner's Service Policy. Coupons attached to the policy entitle you to an initial inspection and the first 100-hour inspection at no charge. If you take delivery from your Dealer, he will perform the initial inspection before delivery of the airplane to

you. If you pick up the airplane at the factory, plan to take it to your Dealer reasonably soon after you take delivery on it. This will permit him to check it over and to make any minor adjustments that may appear necessary. Also, plan an inspection by your Dealer at 100 hours or 180 days, whichever comes first. This inspection also is performed by your Dealer for you at no charge. While these important inspections will be performed for you by any Cessna Dealer, in most cases you will prefer to have the Dealer from whom you purchased the airplane accomplish this work.

Federal Aviation Regulations require that all airplanes have a periodic (annual) inspection as prescribed by the administrator, and performed by a person designated by the administrator. In addition, 100-hour periodic inspections made by an "appropriately-rated mechanic" are required if the airplane is flown for hire. The Cessna Aircraft Company recommends the 100-hour periodic inspection for your airplane. The procedure for this 100-hour inspection has been carefully worked out by the factory and is followed by the Cessna Dealer Organization. The complete familiarity of the Cessna Dealer Organization with Cessna equipment and with factory-approved procedures provides the highest type of service possible at lower cost.

## AIRCRAFT FILE.

There are miscellaneous data, information and licenses that are a part of the aircraft file. The following is a check list for that file. In addition, a periodic check should be made of the latest Federal Aviation Regulations to insure that all data requirements are met.

A. To be displayed in the aircraft at all times:

- (1) Aircraft Airworthiness Certificate (Form FAA-1362B).
- (2) Aircraft Registration Certificate (Form FAA-500A).
- (3) Aircraft Radio Station License (Form FCC-404, if transmitter installed).

B. To be carried in the aircraft at all times:

- (1) Weight and Balance, and associated papers (latest copy of the Repair and Alteration Form, Form FAA-337, if applicable).
- (2) Aircraft Equipment List.

C. To be made available upon request:

- (1) Aircraft Log Book.
- (2) Engine Log Book.

NOTE

Cessna recommends that these items, plus the Owner's Manual, "Cessna Flight Guide" (Flight Computer), and Service Policies, be carried in the aircraft at all times.

Most of the items listed are required by the United States Federal Aviation Regulations. Since the regulations of other nations may require other documents and data, owners of exported aircraft should check with their own aviation officials to determine their individual requirements.

# LUBRICATION AND SERVICING PROCEDURES

Specific servicing information is provided here for items requiring daily attention. A Servicing Intervals Check List is included to inform the pilot when to have other items checked and serviced.

## DAILY

### FUEL TANK FILLERS:

Service after each flight with 80/87 minimum grade fuel. The capacity of each wing tank is 13 gallons for standard fuel tanks, 19 gallons for optional long range tanks.

### FUEL STRAINER:

Before first flight of the day and after each refueling, pull out fuel strainer drain knob (located just inside cowl access door) for about four seconds, to clear fuel strainer of possible water and sediment. Release drain knob, then check that strainer drain is closed after draining. If water is observed, there is a possibility that the wing tank sumps contain water. Thus, the wing tank sump drain plugs and fuel line drain plug should be removed to check for presence of water.

### OIL FILLER:

When preflight check shows low oil level, service with aviation grade engine oil; SAE 40 above 40°F and SAE 10W30 or SAE 20 below 40°F. (Multi-viscosity oil with a range of SAE 10W30 is recommended for improved starting in cold weather.) Detergent or dispersant oil, conforming to Continental Motors Specification MHS-24A, must be used. Your Cessna Dealer can supply approved brands of oil.

### NOTE

To promote faster ring seating and improved oil control, your Cessna was delivered from the factory with straight mineral oil (non-detergent). This "break-in" oil should be used only for the first 20 to 30 hours of operation, at which time it must be replaced with detergent oil.

### OIL DIPSTICK:

Check oil level before each flight. Do not operate on less than 4 quarts. To minimize loss of oil through breather, fill to 5 quart level for normal flights of less than 3 hours. For extended flight, fill to 6 quarts. If optional oil filter is installed, one additional quart is required when the filter element is changed.

# SERVICING INTERVALS CHECK LIST

## EACH 50 HOURS

BATTERY -- Check and service. Check oftener (at least every 30 days) if operating in hot weather.

ENGINE OIL AND OIL FILTER -- Change engine oil and replace filter element. If optional oil filter is not installed, change oil and clean screen every 25 hours. Change engine oil at least every four months even though less than 50 hours have been accumulated. Reduce periods for prolonged operation in dusty areas, cold climates, or when short flights and long idle periods result in sludging conditions.

### NOTE

After first 20 to 30 hours of engine operation, an initial oil change should be made to remove "break-in" oil and change the filter, if installed.

CARBURETOR AIR FILTER -- Clean or replace. Under extremely dusty conditions, daily maintenance of the filter is recommended.

NOSE GEAR TORQUE LINKS -- Lubricate. When operating under dusty conditions, more frequent lubrication is recommended.

## EACH 100 HOURS

BRAKE MASTER CYLINDERS -- Check and fill.

SHIMMY DAMPENER -- Check and fill.

FUEL STRAINER -- Disassemble and clean.

FUEL TANK SUMP DRAINS -- Drain water and sediment.

FUEL LINE DRAIN PLUG -- Drain water and sediment.

SUCTION RELIEF VALVE INLET FILTER (OPT) -- Clean. Replace at engine overhaul period.

SPARK PLUGS -- Clean, test and regap.

## EACH 500 HOURS

VACUUM SYSTEM AIR FILTER (OPT) -- Replace filter element. Replace sooner if suction gage reading drops to 4.6 in. Hg.

WHEEL BEARINGS -- Lubricate at first 100 hours and at 500 hours thereafter. Reduce lubrication interval to 100 hours when operating in dusty or seacoast areas, during periods of extensive taxiing, or when numerous take-offs and landings are made.

## AS REQUIRED

NOSE GEAR SHOCK STRUT -- Keep filled with fluid and inflated to 20 psi. Do not over-inflate.

## OWNER FOLLOW-UP SYSTEM

---

---

Your Cessna Dealer has an owner follow-up system to notify you when he receives information that applies to your Cessna. In addition, if you wish, you may choose to receive similar notification directly from the Cessna Service Department. A subscription card is supplied in your aircraft file for your use, should you choose to request this service. Your Cessna Dealer will be glad to supply you with details concerning these follow-up programs, and stands ready through his Service Department to supply you with fast, efficient, low cost service.

## PUBLICATIONS

Various publications and flight operation aids are furnished in the aircraft when delivered from the factory. These items are listed below.

- OWNER'S MANUALS FOR YOUR  
AIRCRAFT  
ELECTRONICS
- CESSNA FLIGHT GUIDE (FLIGHT COMPUTER)
- SALES AND SERVICE DEALER DIRECTORY
- DO'S AND DON'TS ENGINE BOOKLET

The following additional publications, plus many other supplies that are applicable to your aircraft, are available from your Cessna Dealer.

- SERVICE MANUALS AND PARTS CATALOGS FOR YOUR  
AIRCRAFT  
ENGINE AND ACCESSORIES  
ELECTRONICS

Your Cessna Dealer has a current catalog of all available Customer Services Supplies, many of which he keeps on hand. If supplies are not in stock, your Cessna Dealer will be happy to order for you.

---

---

## Section V

### OPERATIONAL DATA

The operational data shown on the following pages are compiled from actual tests with the airplane and engine in good condition, and using average piloting technique and best power mixture. You will find this data a valuable aid when planning your flights.

To realize the maximum usefulness from your Cessna, you should take advantage of its high cruising speeds. However, if range is of primary importance, it may pay you to fly at a low cruising RPM, thereby increasing your range and allowing you to make the trip non-stop with ample fuel reserve. The cruise performance table (figure 5-4) should be used to solve flight planning problems of this nature.

In the table (figure 5-4), range and endurance are given for lean mixture from 2500 feet to 12,500 feet. All figures are based on zero wind, 22.5 and 35.0 gallons of fuel for cruise, McCauley 1A101/DCM6948 propeller, 1600 pounds gross weight, and standard atmospheric conditions. Mixture is leaned to maximum RPM. Allowances for fuel reserve, headwinds, take-offs and climb, and variations in mixture leaning technique should be made as no allowances are shown on the chart. Other indeterminate variables such as carburetor metering characteristics, engine and propeller conditions, and turbulence of the atmosphere may account for variations of 10% or more in maximum range.

Remember that the charts contained herein are based on standard day conditions. For more precise power, fuel consumption, and endurance information, consult the Cessna Flight Guide (Power Computer) supplied with your aircraft. With the Flight Guide, you can easily take into account temperature variations from standard at any flight altitude.

<b>AIRSPEED CORRECTION TABLE</b>											
<b>(Flaps Up)</b>											
<b>IAS</b>	<b>40</b>	<b>50</b>	<b>60</b>	<b>70</b>	<b>80</b>	<b>90</b>	<b>100</b>	<b>110</b>	<b>120</b>	<b>130</b>	<b>140</b>
<b>CAS</b>	<b>51</b>	<b>57</b>	<b>65</b>	<b>73</b>	<b>82</b>	<b>91</b>	<b>100</b>	<b>109</b>	<b>118</b>	<b>127</b>	<b>136</b>
<b>(Flaps Down)</b>											
<b>IAS</b>	<b>40</b>	<b>50</b>	<b>60</b>	<b>70</b>	<b>80</b>	<b>90</b>	<b>100</b>				
<b>CAS</b>	<b>49</b>	<b>55</b>	<b>63</b>	<b>72</b>	<b>81</b>	<b>89</b>	<b>98</b>				

Figure 5-1.







<b>= Power Off = STALLING SPEEDS MPH = CAS</b>				
<b>Gross Weight</b> 1600 lbs.	<b>ANGLE OF BANK</b>			
				
<b>CONDITION</b>	<b>0°</b>	<b>20°</b>	<b>40°</b>	<b>60°</b>
<b>Flaps UP</b> 	<b>55</b>	<b>57</b>	<b>63</b>	<b>78</b>
<b>Flaps 20°</b> 	<b>49</b>	<b>51</b>	<b>56</b>	<b>70</b>
<b>Flaps 40°</b> 	<b>48</b>	<b>49</b>	<b>54</b>	<b>67</b>

Figure 5-2.

<b>— TAKE-OFF DISTANCE —</b>											FLAPS RETRACTED		HARD SURFACE RUNWAY	
GROSS WT. LBS.	IAS 50 FT. MPH	HEAD WIND KNOTS	AT SEA LEVEL & 59° F.		AT 2500 FT. & 50° F.		AT 5000 FT. & 41° F.		AT 7500 FT. & 32° F.					
			GROUND RUN	TOTAL TO CLEAR 50 FT. OBS	GROUND RUN	TOTAL TO CLEAR 50 FT. OBS	GROUND RUN	TOTAL TO CLEAR 50 FT. OBS	GROUND RUN	TOTAL TO CLEAR 50 FT. OBS				
1600	64	0	735	1385	910	1680	1115	1985	1360	2440				
		10	500	1035	630	1250	780	1510	970	1875				
		20	305	730	395	890	505	1090	640	1375				

NOTES: 1. Increase the distances 10% for each 35° F. increase in temperature above standard for the particular altitude.  
 2. For operation on a dry, grass runway, increase distances (both "ground run" and "total to clear 50 ft. obstacle") by 7% of the "total to clear 50 ft. obstacle" figure.

735 FT = 224 m  
 1385 FT = 422 m

<b>— MAXIMUM RATE-OF-CLIMB DATA —</b>									
GROSS WEIGHT LBS.	AT SEA LEVEL & 59° F.			AT 5000 FT. & 41° F.			AT 10000 FT. & 23° F.		
	IAS, MPH	RATE OF CLIMB FT. /MIN.	FUEL USED, GAL.	IAS, MPH	RATE OF CLIMB FT. /MIN.	FUEL USED FROM S.L., GAL.	IAS, MPH	RATE OF CLIMB FT. /MIN.	FUEL USED FROM S.L., GAL.
1600	73	670	0.6	69	440	1.6	65	220	3.0

NOTES: 1. Flaps retracted, full throttle, mixture leaned to smooth operation above 5000 ft.  
 2. Fuel used includes warm-up and take-off allowances.  
 3. For hot weather, decrease rate of climb 15 ft./min. for each 10° F above standard day temperature for particular altitude.

<b>— LANDING DISTANCE —</b>										FLAPS LOWERED TO 40° - POWER OFF		HARD SURFACE RUNWAY - ZERO WIND	
GROSS WEIGHT LBS.	APPROACH SPEED, IAS, MPH	AT SEA LEVEL & 59° F.		AT 2500 FT. & 50° F.		AT 5000 FT. & 41° F.		AT 7500 FT. & 32° F.					
		GROUND ROLL	TOTAL TO CLEAR 50 FT. OBS	GROUND ROLL	TOTAL TO CLEAR 50 FT. OBS	GROUND ROLL	TOTAL TO CLEAR 50 FT. OBS	GROUND ROLL	TOTAL TO CLEAR 50 FT. OBS				
1600	58	445	1075	470	1135	495	1195	520	1255				

NOTES: 1. Decrease the distances shown by 10% for each 4 knots of headwind.  
 2. Increase the distance by 10% for each 60° F. temperature increase above standard.  
 3. For operation on a dry, grassy runway, increase distances (both "ground roll" and "total to clear 50 ft. obstacle") by 20% of the "total to clear 50 ft. obstacle" figure.

59F = 15°C  
 69F = 20.5°C

Figure 5-3.

# CRUISE PERFORMANCE

WITH LEAN MIXTURE

ALTITUDE	RPM	%BHP	TAS MPH	GAL/HR.	END. HOURS		RANGE, MILES	
					STANDARD	LONG RANGE	STANDARD	LONG RANGE
					22.5 GAL.	35 GAL.	22.5 GAL.	35 GAL.
2500	2750	92	121	7.0	3.2	5.0	390	605
	2700	87	119	6.6	3.4	5.3	410	635
	2600	77	114	5.8	3.9	6.1	445	690
	2500	68	108	5.1	4.4	6.9	475	740
	2400	60	103	4.6	4.9	7.7	505	790
	2300	53	96	4.1	5.5	8.6	535	830
	2200	46	89	3.6	6.2	9.7	550	860
	2100	40	79	3.2	7.0	10.9	555	865
5000	2750	85	121	6.4	3.5	5.5	425	660
	2700	80	118	6.0	3.8	5.8	445	690
	2600	71	113	5.3	4.2	6.6	475	740
	2500	63	107	4.8	4.7	7.4	505	790
	2400	56	101	4.3	5.3	8.2	530	830
	2300	49	93	3.8	5.9	9.2	550	860
	2200	43	84	3.4	6.6	10.3	560	870
	2100	37	71	3.0	7.5	11.7	540	835
7500	2700	74	117	5.5	4.1	6.3	480	745
	2600	66	111	4.9	4.6	7.1	505	790
	2500	58	105	4.4	5.1	7.9	535	830
	2400	52	98	4.0	5.7	8.8	555	860
	2300	45	89	3.6	6.3	9.8	560	875
	2200	40	77	3.2	7.1	11.1	550	850
10,000	2700	68	116	5.1	4.4	6.8	510	790
	2600	61	109	4.6	4.9	7.6	535	830
	2500	54	102	4.1	5.4	8.5	555	865
	2400	48	93	3.7	6.1	9.4	565	880
	2300	42	82	3.3	6.8	10.6	555	860
12,500	2650	60	110	4.5	5.0	7.8	550	855
	2600	56	106	4.3	5.3	8.2	555	865
	2500	50	97	3.9	5.8	9.1	565	880
	2400	44	86	3.5	6.5	10.1	560	870

- NOTES: 1. Maximum cruise is normally limited to 75% power.  
 2. In the above calculations of endurance in hours and range in miles, no allowances were made for take-off or reserve.

Figure 5-4.

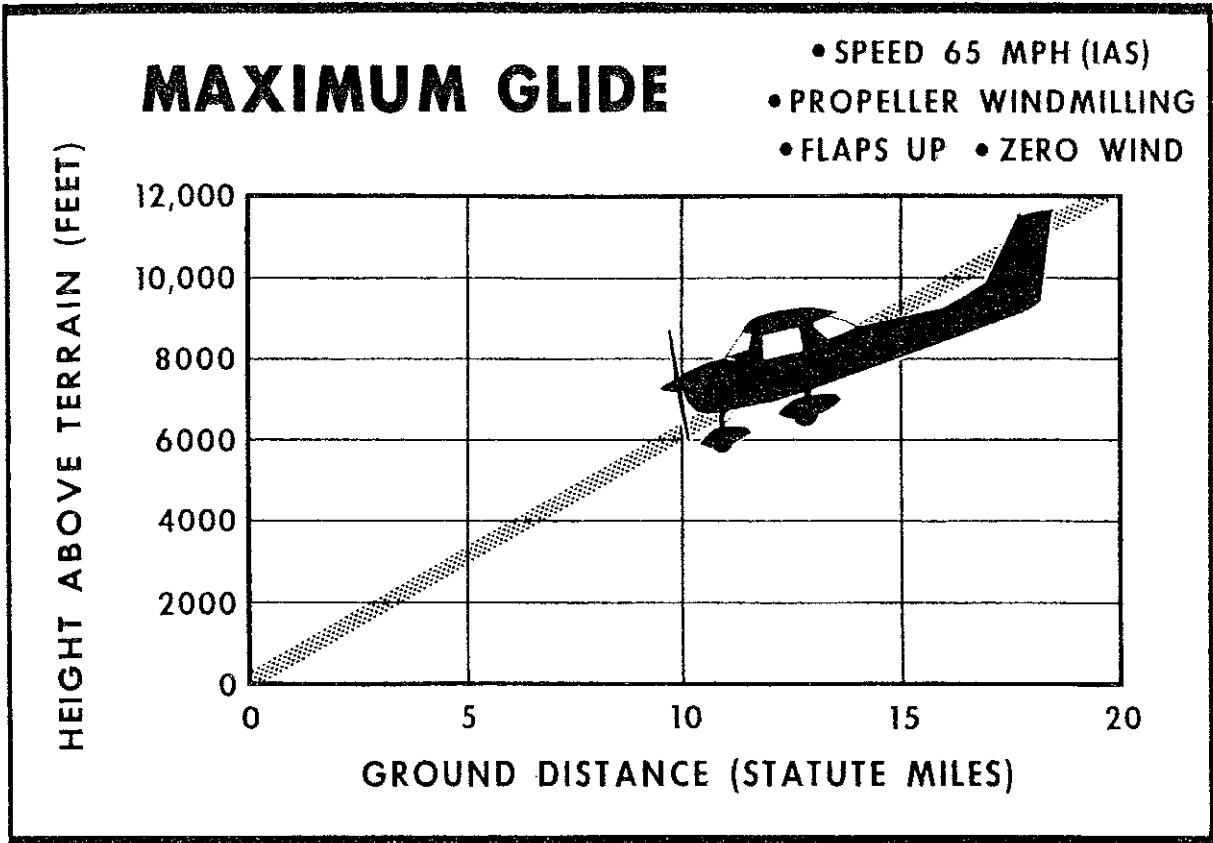

Figure 5-5.

# *Section VI*

---

## OPTIONAL SYSTEMS

This section contains a description, operating procedures, and performance data (when applicable) for some of the optional equipment which may be installed in your Cessna. Owner's Manual Supplements are provided to cover operation of other optional equipment systems when installed in your airplane. Contact your Cessna Dealer for a complete list of available optional equipment.

### **LONG RANGE FUEL TANKS**

Special wings with long range fuel tanks are available to replace the standard wings and fuel tanks for greater endurance and range. Each tank has a total capacity of 19 gallons. Usable fuel in each long range tank, for all flight conditions, is 17.5 gallons.

### **COLD WEATHER EQUIPMENT**

#### **WINTERIZATION KIT.**

For continuous operation in temperatures consistently below 20°F, the Cessna winterization kit should be installed to improve engine operation. The kit consists of a shield to partially cover the cowl nose cap opening, the addition of heat ducting from the right exhaust manifold for additional cabin heat, a carburetor airbox heat outlet cap, and insulation for the engine crankcase breather line. Once installed, the crankcase breather insulation is approved for permanent use in both cold and hot weather.

## **GROUND SERVICE PLUG RECEPTACLE.**

A ground service plug receptacle may be installed to permit the use of an external power source for cold weather starting and during lengthy maintenance work on the electrical and electronic equipment.

Just before connecting an external power source (generator type or battery cart), the master switch should be turned "ON." This is especially important since it will enable the battery to absorb transient voltages which otherwise might damage the transistors in the electronic equipment.

The battery and external power circuits have been designed to completely eliminate the need to "jumper" across the battery contactor to close it for charging a completely "dead" battery. A special fused circuit in the external power system supplies the needed "jumper" across the contacts so that with a "dead" battery and an external power source applied, turning the master switch "ON" will close the battery contactor.

## **FUEL TANK QUICK-DRAIN VALVE KIT**

Two fuel tank quick-drain valves and a fuel sampler cup are available as a kit to facilitate daily draining and inspection of fuel in the main tanks for the presence of water and sediment. The valves replace existing fuel tank drain plugs located at the lower inboard area of the wing. The fuel sampler cup, which may be stowed in the map compartment, is used to drain the valves. The sampler cup has a probe in the center of the cup. When the probe is inserted into the hole in the bottom of the drain valve and pushed upward, fuel flows into the cup to facilitate visual inspection of the fuel. As the cup is removed, the drain valve seats, stopping the flow of fuel.

## RADIO TRANSMITTER SELECTOR SWITCH

Operation of the radio equipment is normal as covered in the respective radio manuals. When the aircraft is equipped with more than one radio having transmitter capabilities, a transmitter selector switch is installed to switch the microphone to the radio unit the pilot desires to use for transmission. The switch is located in the upper center portion of the instrument panel and is labeled "TRANS, 1 and 2." Placing the switch in the upper position, labeled "1," switches the microphone to the upper transmitter; the lower position, labeled "2," switches the microphone to the lower transmitter.

## TRUE AIRSPEED INDICATOR

A true airspeed indicator is available to replace the standard airspeed indicator in your airplane. The true airspeed indicator has a calibrated rotatable ring which works in conjunction with the airspeed indicator dial in a manner similar to the operation of a flight computer.

TO OBTAIN TRUE AIRSPEED, rotate ring until pressure altitude is aligned with outside air temperature in degrees Fahrenheit. Then read true airspeed on rotatable ring opposite airspeed needle.

### NOTE

Pressure altitude should not be confused with indicated altitude. To obtain pressure altitude, set barometric scale on altimeter to "29.92" and read pressure altitude on altimeter. Be sure to return altimeter barometric scale to original barometric setting after pressure altitude has been obtained.

# WING LEVELER

A wing leveler may be installed to augment the lateral and directional stability of the airplane. The system uses the Turn Coordinator for roll and yaw sensing. Vacuum pressure, from the engine-driven vacuum pump, is routed from the Turn Coordinator to cylinder-piston servo units attached to the aileron and rudder control systems. As the airplane deviates from a wing level attitude or a given direction, vacuum pressure in the servo units is increased or relieved as needed to actuate the ailerons and rudder to oppose the deviations. The rudder action effectively corrects adverse yaw induced by the ailerons.

A separately mounted push-pull control knob, labeled "WING LVLR," is provided at the lower center of the instrument panel to turn the system on and off. A "ROLL TRIM" control knob on the Turn Coordinator is used for manual roll trim control to compensate for asymmetrical loading of fuel and passengers, and to optimize system performance in climb, cruise and let-down.

## OPERATING CHECK LIST

### TAKE-OFF.

- (1) "WING LVLR" Control Knob -- Check in off position (full in).

### CLIMB.

- (1) Adjust elevator trim for climb.
- (2) "WING LVLR" Control Knob -- Pull control knob "ON".
- (3) "ROLL TRIM" Control Knob -- Adjust for wings level attitude.

### CRUISE.

- (1) Adjust power and elevator trim for level flight.
- (2) "ROLL TRIM" Control Knob -- Adjust as desired.

## **DESCENT.**

- (1) Adjust power and elevator trim for desired speed and rate of descent.
- (2) "ROLL TRIM" Control Knob -- Adjust as desired.

## **LANDING.**

- (1) Before landing, push "WING LVLR" control knob full in to the off position.

## **EMERGENCY PROCEDURES**

If a malfunction should occur, the system is easily overpowered with pressure on the control wheel. The system should then be turned off. In the event of partial or complete vacuum failure, the wing leveler will automatically become inoperative. However, the Turn Coordinator used with the wing leveler system will not be affected by loss of vacuum since it is designed with a "back-up" system enabling it to operate from either vacuum or electrical power in the event of failure of one of these sources.

## **OPERATING NOTES**

- (1) The wing leveler system may be overpowered at any time without damage or wear. However, for extended periods of maneuvering it may be desirable to turn the system off.

- (2) It is recommended that the system not be engaged during take-off and landing. Although the system can be easily overpowered, servo forces could significantly alter the manual "feel" of the aileron control, especially should a malfunction occur.

# ALPHABETICAL INDEX

---

---

## A

After Landing, 1-3  
Air and Heat Controls, Cabin, 1-4  
Air Filter, Carburetor, 4-8  
Air Filter, Vacuum System, 4-8  
Aircraft Registration Number, 1-4  
Airplane,  
    before entering, 1-1  
    file, 4-5  
    ground handling, 4-1  
    mooring, 4-1  
    secure, 1-3  
Airspeed Correction Table, 5-2  
Airspeed Indicator, 1-4, 6-3  
    markings, 3-2  
Airspeed Limitations, 3-2  
Alternator, 2-4  
Alternator Circuit Breaker, 1-4  
Alternator Field Circuit Breaker,  
    2-4  
Altimeter, 1-4  
Aluminum Surfaces, 4-3  
Ammeter, 1-4, 2-3, 2-4  
Authorized Operations, 3-1

## B

Baggage, Capacity, inside cover  
Baggage Loading/Tie-Down, 3-5  
Battery, 2-4, 4-8  
Battery Contactor, 2-4  
Beacon, Flashing, 2-5  
Bearing, Indicator, 1-4  
Before Entering the Airplane, 1-1  
Before Landing, 1-3  
Before Starting the Engine, 1-1

Before Take-Off, 1-2, 2-8  
    magneto check, 2-8  
    warm-up, 2-8  
Brake Master Cylinders, 4-8  
Brake System, Parking, 2-5

## C

Cabin Air and Heat Controls, 1-4  
Cabin Heating and Ventilating  
    System, 2-5  
Capacity,  
    baggage, inside cover  
    fuel, inside covers  
    oil, inside covers  
Carburetor, 2-2  
    air filter, 4-7  
    heat control knobs, 1-4  
Care,  
    exterior, 4-2, 4-3  
    interior, 4-4  
    propeller, 4-3  
Center of Gravity Moment  
    Envelope, 3-7  
Check List, Servicing Intervals, 4-8  
Cigar Lighter, 1-4, 2-4  
Climb, 1-2, 2-9  
    climb data, 2-9  
    climb speeds, 2-10  
    go-around climb, 2-10  
    maximum performance, 1-3  
    maximum rate-of-climb data,  
        5-3  
    normal, 1-2  
Clock, 1-4, 2-4  
Cold Weather Equipment, 6-1  
    winterization kit, 6-1

Cold Weather Operation, 2-12  
Control Wheel Map Light, 2-4  
Correction Table, Airspeed, 5-2  
Crosswind Landings, 2-12  
Crosswind Take-Offs, 2-9  
Cruise Performance, Optimum,  
2-10  
Cruise Performance Table, 5-4  
Cruising, 1-3, 2-10

## D

Diagram,  
    baggage, loading/tie-down, 3-4  
    electrical, 2-4  
    exterior inspection, iv  
    fuel, 2-2  
    maximum glide, 5-5  
    principal dimensions, ii  
    taxiing, 2-6  
Dimensions, Principal, ii  
Dipstick, Oil, 4-7  
Directional Gyro, 1-4  
Distance Table,  
    landing, 5-3  
    take-off, 5-3

## E

Electrical System, 2-3  
    alternator, 2-4  
    ammeter, 1-4, 2-3, 2-4  
    battery, 2-4, 4-8  
    battery contactor, 2-4  
    cigar lighter, 1-4, 2-4  
    clock, 1-4, 2-4  
    flashing beacon, 2-5  
    fuses and circuit breakers,  
        2-3, 2-4  
    ignition switch, 1-4, 2-4

magnetos, 2-4  
master switch, 1-4, 2-4  
regulator, 2-4  
schematic, 2-4  
starter, 2-4  
starter switch, 1-4, 2-4  
switches, 1-4

Elevator Trim Control Wheel, 1-4  
Empty Weight, inside cover  
Engine, inside cover  
    before starting, 1-1  
    instrument markings, 3-3  
    oil and oil filter, 4-8  
    oil dipstick, 4-7  
    oil filler, 4-7  
    operation limitations, 3-3  
    primer, 1-4, 2-2  
    starting, 1-1, 2-7  
Equipment, Cold Weather, 6-1  
Exterior Care, 4-2, 4-3  
Exterior Inspection Diagram, iv

## F

File, Aircraft, 4-5  
Filler, Oil, 4-7  
Filter, Carburetor Air, 4-8  
Filter, Oil, 4-8  
Flap Settings, 2-9  
Flashing Beacon, 2-5  
Flight Hour Recorder, 2-4  
Fuel System, 2-1  
    capacity, inside covers  
    carburetor, 2-2  
    fuel line drain plug, 4-8  
    fuel tanks, 2-2  
    fuel tank fillers, 4-7  
    fuel tank quick-drain valve kit,  
        6-2  
    fuel tank sump drains, 4-8  
    long range fuel tanks, 6-1

mixture control knob, 1-4, 2-2  
primer, 1-4, 2-2  
quantity data, 2-1  
quantity indicators, 1-4, 3-3  
schematic, 2-2  
shut-off valve, 2-2  
strainer, 2-1, 2-2, 4-7, 4-8  
strainer drain knob, 2-1  
Fuses and Circuit Breakers, 1-4,  
2-3, 2-4

## G

Go-Around Climb, 2-10  
Gross Weight, inside cover, 3-1  
Ground Handling, 4-1  
Ground Service Plug Receptacle,  
2-4, 6-2  
Gyro, Directional, 1-4  
Gyro Horizon, 1-4

## H

Handling Airplane on Ground, 4-1  
Heating and Ventilating System,  
Cabin, 2-5  
Hydraulic Fluid, inside back cover

## I

Ignition-Starter Switch, 1-4, 2-4  
Ignition Switch, 1-4, 2-4  
Indicator,  
    airspeed, 1-4, 6-3  
    vertical speed, 1-4  
Indicators, Fuel Quantity, 1-4, 3-3  
Inspection Diagram, Exterior, iv  
Inspection Service and Inspection  
    Periods, 4-4  
Instrument Markings, Engine, 3-3  
Interior Care, 4-4

## L

Landing, inside cover, 2-11  
    after, 1-3  
    before, 1-3  
    crosswind, 2-12  
    distance table, 5-3  
    normal, 1-3  
    short field, 2-11

Limitations,  
    airspeed, 3-2  
    engine operation, 3-3

Loading, Power, inside cover

Loading Graph, 3-6

Loading Problem, Sample, 3-5

Long Range Fuel Tanks, 6-1

Lubrication and Servicing  
    Procedures, 4-7

## M

Magnetos, 2-4

Maneuvers - Utility Category, 3-1

Map Compartment, 1-4

Marker Beacon Lights, 1-4

Markings, Instrument, 3-3

Master Cylinders, Brake, 4-8

Master Switch, 1-4, 2-4

Maximum Glide, 5-5

Maximum Performance Climb, 1-3

Maximum Performance Take-Off,  
    1-2

Maximum Rate-of-Climb Data, 5-3

Microphone, 1-4

Mixture Control Knob, 1-4, 2-2

Moment Envelope, Center of  
    Gravity, 3-7

Mooring Your Airplane, 4-1

## N

Normal Climb, 1-2

Normal Landing, 1-3  
Normal Take-Off, 1-2  
Nose Gear Shock Strut, 4-8  
Nose Gear Torque Links, 4-8

## O

Oil System,  
    capacity, inside covers  
    dipstick, 4-7  
    engine oil, 4-8, inside back  
    cover  
    filler, 4-7  
    filter, 4-8  
    temperature gage, 1-4, 3-3  
    pressure gage, 1-4, 3-3  
    pressure switch, 2-4  
Omni Course Indicator, 1-4  
Operation, Cold Weather, 2-12  
Operation Limitations, Engine, 3-2  
Operations Authorized, 3-1  
Optimum Cruise Performance, 2-10  
Owner Follow-Up System, 4-9

## P

Painted Surfaces, 4-2  
Parking Brake Control Knob, 1-4  
Parking Brake System, 2-5  
Performance Charts, 2-9  
Performance - Specifications,  
    inside cover  
Power, inside cover  
Power Loading, inside cover  
Primer, Engine, 1-4, 2-2  
Principal Dimensions, ii  
Propeller, inside cover  
    care, 4-3  
Publications, 4-9

Index-4

## Q

Quantity Data, Fuel, 2-1  
Quantity Indicators, Fuel, 1-4, 3-3  
Quick-Drain Valve Kit, Fuel, 6-2

## R

Radio, 1-4  
Radio Dial Light Rheostat, 1-4  
Radio Transmitter Selector  
    Switch, 1-4, 6-3  
Range, inside cover  
Rate-of-Climb, inside cover  
Rate-of-Climb Data Table, 5-3  
Rear View Mirror, 1-4  
Registration Number, Aircraft, 1-4  
Regulator, Voltage, 2-4

## S

Sample Loading Problem, 3-5  
Secure Aircraft, 1-3  
Service Ceiling, inside cover  
Servicing and Lubrication, 4-6  
Servicing Intervals Check List, 4-8  
Servicing Requirements Table,  
    inside back cover  
Shimmy Dampener, 4-8  
Short Field Landing, 2-11  
Shut-Off Valve, Fuel, 2-2  
Spark Plugs, 4-8  
Specifications - Performance,  
    inside cover  
Speed, inside cover  
Speeds, Climb, 2-10  
Stalls, 2-11  
    speed chart, 5-2

Starter, 2-4  
Starter Contactor, 2-4  
Starter Switch, 1-4, 2-4  
Starting Engine, 1-1. 2-7  
    before, 1-1  
Strainer, Fuel, 2-2, 4-6, 4-8  
Suction Gage, 1-4  
Suction Relief Valve Inlet Screen,  
    4-8  
Surfaces,  
    aluminum, 4-3  
    painted, 4-2  
System,  
    cabin heating and ventilating,  
        2-5  
    electrical, 2-3  
    fuel, 2-1  
    owner follow-up, 4-9  
    parking brake, 2-5

## T

Table of Contents, iii  
Tachometer, 1-4, 3-3  
Take-Off, inside cover, 1-2, 2-8  
    before take-off, 1-2, 2-8  
    crosswind, 2-9  
    distance table, 5-3  
    flap settings, 2-9  
    maximum performance, 1-2  
    normal, 1-2  
    performance charts, 2-9  
    power checks, 2-8  
Taxiing, 2-7  
    diagram, 2-6  
Throttle, 1-4, 2-2

Tire Pressure, inside back cover  
Trim Control Wheel, Elevator,  
    1-4  
True Airspeed Indicator, 6-3  
Turn Coordinator, 1-4

## U

Utility Category, Maneuvers, 3-1

## V

Vacuum System Air Filter, 4-8  
Vertical Speed Indicator, 1-4

## W

Weight,  
    empty, inside cover  
    gross, inside cover, 3-1  
Weight and Balance, 3-3  
    center of gravity envelope, 3-7  
    loading graph, 3-6  
    sample loading problem, 3-5  
Wheel Bearings, 4-8  
Windshield - Windows, 4-2  
Wing Flap Switch, 1-4  
Wing Leveler, 6-4  
    emergency procedures, 6-5  
    operating check list, 6-4  
    operating notes, 6-5  
Wing Leveler Control Knob, 1-4  
Wing Loading, inside cover  
Winterization Kit, 6-1